



**Features**

Two-piece chevron PFA stem packing design with compensating spring packing.

- improves sealing integrity.
- high pressure valve but with compact design.

**Flow Data**

Cv are measured at the valve. Therefore restrictions at end connections may reduce flow.

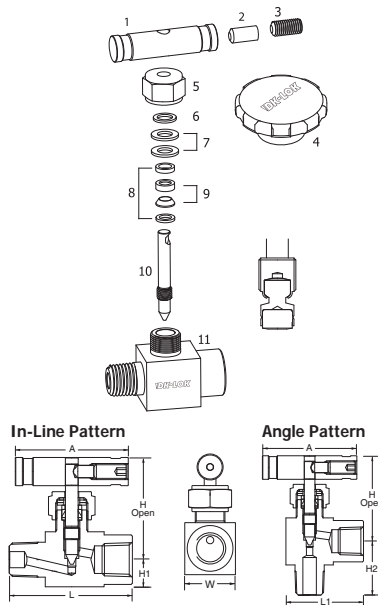
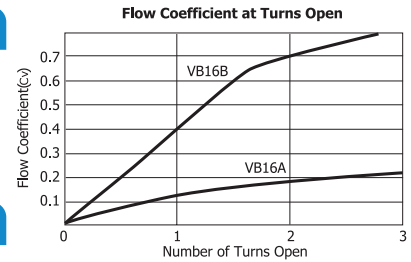

**Materials of Construction**

Components		Material Grade
1	Bar Handle	SS316/ASTM A276
2	Position Pin	
3	Set Screw	Grade B8 TYPE 304/A193
4	Optional Round Handle	Nylon with brass insert
5	Cap Nut	SS316/ASTM A276
6	Gland	
7	Spring Packing (2)	S17700/A693
8	Upper / Lower Gland (2)	SS316/ASTM A276
9	Chevron Packing (2)	PFA/D3307
10	Standard Vee Stem	SS316/ASTM A276
10.1	Optional Soft Stem	Kel-F (PTFE)
11	Body	SS316/ASTM A276

**Pressure-Temperature Ratings**

Temperature rating of VB16A & B series with nonrotating Kel-F soft seat -65 to 200 °F (-53 to 93 °C), Vee stem metal seat -65 to 450 °F (-53 to 232 °C).

Non-rotating soft seat for repetitive shut-off on gas

ASME Class	2500
Material Group	2.2
Material	SS316
Temperature °F (°C)	Working Pressure, psig (bar)
-65 to 100 (-53 to 37)	6000 (413)
200 (93)	5160 (355)
250 (121)	4910 (338)
300 (148)	4660 (321)

**Ordering Information and Dimensions**

Ordering Number	End Connection		Dimensions, mm(in.)			H2	L	L1	A	W
			Orifice/Cv	H	H1					
VB16A-	D4T-S	1/4 in. DK-Lok		3.2 (0.125) Cv 0.21	43.1 (1.69)	10.7 (0.42)	29.5 (1.16)	62.5 (2.46)	39.9 (1.57)	44.5 (1.75)
	F4N-S	1/4 in. Female NPT								
	M4N-S	1/4 in. Male NPT								
	MF4N-S	1/4 in. Male	1/4 in. Female							
VB16B-	D6T-S	3/8 in. DK-Lok		6.4 (0.25) Cv 0.73	58.0 (2.28)	16.8 (0.66)	-	78.2 (3.08)	-	64.0 (2.52)
	D8T-S	1/2 in. DK-Lok								
	F6N-S	3/8 in. Female NPT								
	F8N-S	1/2 in. Female NPT								
	MF6N-S	3/8 in. Male NPT	3/8 in. Female NPT							
	MF8N-S	1/2 in. Male NPT	1/2 in. Female NPT							
	MF12N8N-S	3/4 in. Male NPT	1/2 in. Female NPT							

**Angle Pattern** : Valves with L1 dimension available for Angle Pattern. \* Round handle diameter.  
To order a valve with soft stem, insert -K in the ordering number. i.e., VB16A-D4T-K-S

**Factory Test**

Every valve is tested with the nitrogen @ 68 bar (1,000 psig) for leakage at the seat to a maximum allowance leak rate of 0.1 scc /min. The stem packing is tested for no detectable leakage.

**Safe Valve Selection**

The selection of a valve for any application or system design must be considered to ensure safe performance. Valve function, valve rating, material compatibility, proper installation, operation and maintenance Remain the sole responsibility of the system designer and the user. DK-Lok accepts no liability for any improper selection, installation, operation or maintenance.

**Features**

- **Packing bolt** permits packing adjustment externally.
- **Chevron PTFE packing** design provides far improved sealing integrity.
- **Packing** below stem threads is to isolate **threads** from system fluid and lubricant washout.
- **Non-rotating** stem tip at closure for long-life and leak-tight shutoff.
- **Lock plate** ensures the valve fastened to the body.
- **NACE MR0175/ISO 15156-3** applicable

**Pressure-Temperature Ratings**

Body Material	Packing material	Temperature Rating	Pressure Rating @ 38 °C (100 °F)	Pressure Rating @ Max. Temp.
Stainless steel	PTFE	-54 to 232 °C (-65 to 450 °F)	689 bar (10,000 psig)	285 bar @ 232 °C 4,130 psig @ 450 °F
	Grafoil	-54 to 648 °C (-65 to 1,200 °F)		118 bar @ 648 °C 1,715 psig @ 1,200 °F
Carbon steel	PTFE	-29 to 176 °C (-20 to 350 °F)	689 bar (10,000 psig)	360 bar @ 176 °C (5,230 psig @ 350 °F)
	Grafoil	-29 to 176 °C (-20 to 350 °F)		

**Materials of Construction**

Component	Valve Body Materials	
	Stainless steel	Carbon steel
1. Handle	Stainless steel	Carbon steel
2. Set screw		Carbon steel
3. Cap nut	SS316/A276 or A479	C.Steel/JIS G4051
4. Packing bolt		
5. Gland		SS316/A276 or A479
6. Packing supports	Standard chevron PTFE packing. Optional Grafoil.	
7. Packing		SS316/A276 or A479
8. Bonnet	SS316/A276 or A479	C.Steel/JIS G4051
9. Stem		
10. stem disc	SS630/A564	
11. Lock bolt	Stainless steel	
12. Lock plate	Stainless steel	
13. Body	SS316/A276 or A479	C.Steel/ JIS G4051, White zinc galvanized.

Wetted components listed in blue.  
Grafoil: TM UCAR

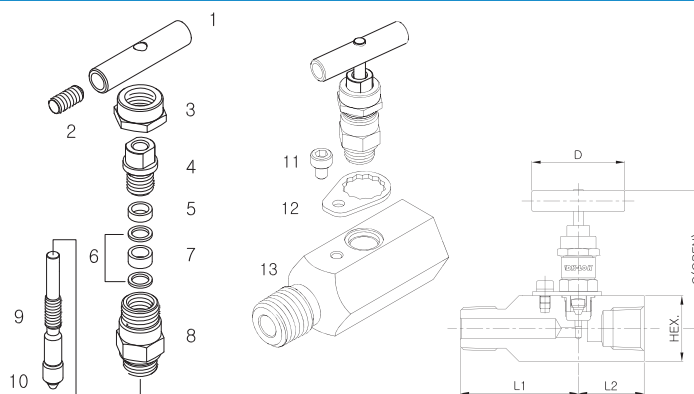

**Ordering Information and Dimensions**

Basic Ordering No.	End Connection		Orifice in. (mm)	Cv	Dimensions, in.(mm)					
	Inlet	Outlet			L	L1	L2	Hex	D	O
V46A-	D-4T-	1/4 DK-Lok	0.185 (4.7)	0.37	3.21 (81.5)	1.59 (40.4)	1.62 (41.1)	1.25 (31.75)	1.77 (45)	2.64 (67.2)
	D-6T-	3/8 DK-Lok		0.64	3.33 (84.5)	1.65 (41.9)	1.68 (42.6)			
	D-8T-	1/2 DK-Lok		0.83	3.54 (90.0)	1.76 (44.7)	1.78 (45.3)			
	F-4N-	1/4 Female NPT		0.83	3.0 (76.2)	1.75 (44.4)	1.25 (31.8)			
	F-6N-	3/8 Female NPT								
	F-8N-	1/2 Female NPT								
	MF-8N-	1/2 Male NPT								
	MF-12N8N-	1/2 Male NPT		1/2 Female NPT	3.5 (88.9)	2.25 (57.1)				

Dimensions shown are for reference only and subject to change.

**How to order**

- To complete ordering number, add material designator **S** for stainless steel or **C** for carbon steel. Example V46A-F8N-S
- To order optional Grafoil packing, insert **GF** to the ordering number. Example V46A-F8N-GF-S
- To order NACE applicable valve, insert **SG** to the ordering number. Example V46A-F8N-GF-SG-S



**Factory test, cleaning and packaging**

- Every valve is factory tested with nitrogen @ 69 bar (1,000 psig) for leakage at the seat to a maximum allowable leak rate of 0.1 SCCM.
- Stem packing is tested for no detectable leakage.
- Every valve is cleaned and packaged in accordance with DK-Lok Corporation cleaning standard DC-01. Optional DC-11 cleaning for oxygen application is available on request.

**Packing adjustment and Actuation Torque**

- Extreme or rapid temperature cycle while valve in service may require packing adjustment.
- Valves that have not been actuated for a period of time may have a higher initial actuation torque.

**Safe Valve Selection**

The selection of a valve for any application or system design must be considered to ensure safe performance. Valve function, valve rating, material compatibility, proper installation, operation and maintenance Remain the sole responsibility of the system designer and the user. DK-Lok accepts no liability for any improper selection, installation, operation or maintenance.