

ASME Accredited
Nuclear & ISO9001
Quality System

Lloyd's
Register

CE



GL



ABS

ABS



for JIS & KS













































ISO 9001 Certified Fitting
and Valve Manufacturer

Bite Type Tube Fittings

Catalog No.02-3
October, 2009



Dk Tech Corporation

<p>BU Straight Union</p>  <p>6</p>	<p>BOLM O-Seal Male Elbow</p>  <p>13</p>	<p>BC Cap</p>  <p>19</p>	<p>BHBLF Hose Bulkhead Female Elbow</p>  <p>24</p>
<p>BL Union Elbow</p>  <p>6</p>	<p>BSLM Banjo Elbow</p>  <p>14</p>	<p>BP Plug</p>  <p>19</p>	<p>BCW Welding Connector</p>  <p>25</p>
<p>BT Union Tee</p>  <p>7</p>	<p>BBTM Male Branch Tee</p>  <p>14</p>	<p>BN Nut</p>  <p>20</p>	<p>BBUW Welding Bulkhead Union</p>  <p>25</p>
<p>BBU Straight Bulkhead Union</p>  <p>7</p>	<p>BRTM Male Run Tee</p>  <p>15</p>	<p>BS Sleeve</p>  <p>20</p>	<p>BA-R Adapter</p>  <p>26</p>
<p>BBL Bulkhead Elbow</p>  <p>8</p>	<p>BBFC Bulkhead Female Connector</p>  <p>15</p>	<p>BHUM Hose Male Union</p>  <p>21</p>	<p>BA-G Adapter (For Copper Gasket)</p>  <p>26</p>
<p>BLMC Long Male Connector</p>  <p>8</p>	<p>BFC Female Connector</p>  <p>16</p>	<p>BHUF Hose Female Union</p>  <p>21</p>	<p>BR Reducer</p>  <p>27</p>
<p>BMC-R Male Connector</p>  <p>9</p>	<p>BGC Gauge Connector</p>  <p>16</p>	<p>BHBM Hose Bulkhead Male Union</p>  <p>22</p>	<p>BLA Positionable Elbow</p>  <p>27</p>
<p>BMC-G Male Connector</p>  <p>10</p>	<p>BLF Female Elbow</p>  <p>17</p>	<p>BHBF Hose Bulkhead Female Union</p>  <p>22</p>	<p>BBTA Positionable Branch Tee</p>  <p>28</p>
<p>BOM Male Connector (For O-ring)</p>  <p>11</p>	<p>BBTF Female Branch Tee</p>  <p>17</p>	<p>BHLM Hose Male Elbow</p>  <p>23</p>	<p>BRTA Positionable Run Tee</p>  <p>28</p>
<p>BLM Male Elbow</p>  <p>12</p>	<p>BRTF Female Run Tee</p>  <p>18</p>	<p>BHLF Hose Female Elbow</p>  <p>23</p>	<p>BAP-1 Air Purge Valve (Tube End)</p>  <p>29</p>
<p>BLLM Long Male Elbow</p>  <p>13</p>	<p>BJ Jig</p>  <p>18</p>	<p>BHBLM Hose Bulkhead Male Elbow</p>  <p>24</p>	<p>BAP-2 Air Purge Valve (Thread End)</p>  <p>29</p>

DK Bite Type Tube Fitting is manufactured to JIS B2351 & KS B1535 under strict ISO 9001 procedure and Type approved by DNV - Norway.

Standard of DK Bite Type Fitting

Bite type fitting consists of three parts : Body, Sleeve and Nut, and is designed to work over medium and heavy wall tubing. See Fig-i

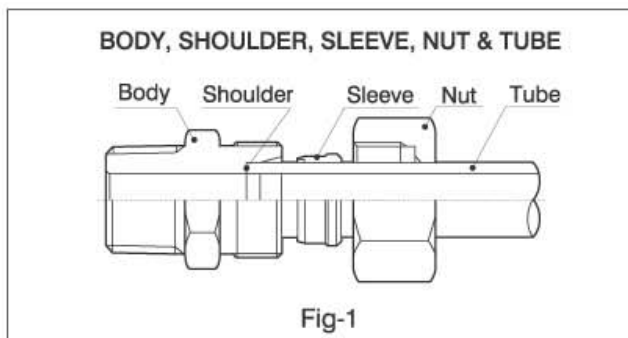

When tightening nut, sleeve is driven forward on the tube then bites the tube with the edge of sleeve, this is how sealing is achieved and results in internal ridge inside the tube. See Fig-2

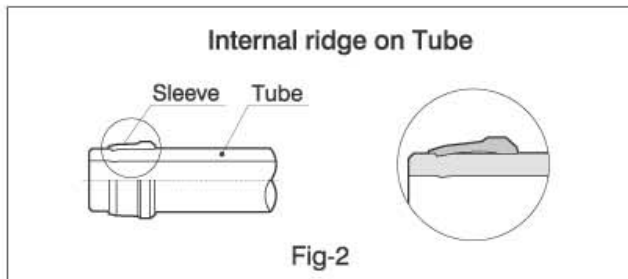

Typical Raw Material List

Parts	Carbon Steel	Stainless Steel	Brass
Forged Body	JISG4051 S20C-S48C	SUS316-SUS304	JIS H3250 C3771
Bar stock Body	JISG4051 S20C-S48C	SUS316-SUS304	JIS H3250 C3604
Cold Formed Nut	JISG4051 S10C-S20C	SUS316-SUS304	
Bar stock Nut	JISG4051 S20C-S48C	SUS316-SUS304	JIS H3250 03604
Sleeve	JISG4051 S10C	SUS316-SUS304	JIS H3250 C3604

Fitting Material Pressure Ranges

(Kg f/cm²)

O.D (mm)	4-5	6-22	25-28	30-38	40-50
C.steel & S.Steel	500	400	350	250	210
Brass	250	210	170	150	120

Pressure is rated at ambient temperature.

Allowable working temperature

1. For fitting materials

Material	Temperature
Steel	-40°C to 12000 (DIN 3859)
Brass	-60°C to 175°C
Stainless Steel	-60°C to 400°C (DIN 17440)

Note : temperature limits can greatly depend on the medium.

2. For Elastomer seals

Material	Temperature
NBR (e.g. Perbunan [®])	-35°C to 100°C
FPM (e.g. Viton [®])	-25°C to 200°C
PTEF (e.g. Teflon [®])	-60°C to 240°C

Note : When seal is used in the fitting, compare allowable working temperature between seal and fitting material and apply the lowest temperature

Pressure reduction with temperature

Following pressure reduction is applicable to the rating in the fitting material pressure range for the elevated temperatures.

Materials of fittings	Temperature Range	Reduction of pressure
Steel	40°C to 120°C	-
Brass	-60°C to 175°C	30%
Stainless Steel	-60°C to 20°C	-
Stainless Steel	50°C	4%
Stainless Steel	100°C	11%
Stainless Steel	200°C	20%
Stainless Steel	300°C	29%
Stainless Steel	400°C	33%

Bite Type Tube Fittings

Using the same tube material as fitting is essential for the same pressure reduction, thermal compatibility and corrosion resistance.

Surface Protection

Steel Bite type fittings are black zinc plated. Yellow or white zinc plating is optional. Steel weldable fittings are phosphated.

Stainless steel Bite type fittings are passivated.

Brass Bite type fittings are acid cleaned. Optional chrome plating on brass fitting is available.

Tubing Selection

* Carbon Steel :

Seamless, welded, fully annealed and redrawn tube suitable for bending with maximum hardness Rockwell B72

* Stainless Steel :

Seamless, welded, fully annealed and redrawn tube suitable for bending with maximum hardness Rockwell B90

* Copper :

For seamless coils, soft or light annealed, maximum hardness Rockwell F55.

For straight lengths, light drawn and general purpose, maximum hardness 60 on Rockwell 30T scale.

Note : Do not bend a tube placed in the fittings. This may cause leakage.

Assembly Instructions

Preparing the tube

Tube and Bite type tube fitting are an intrinsic part of a tube system, therefore Dk strongly advises you to take care in handling the tube in order to have the pressure-tight system.

1. Cut the tube square
2. Deburr inside and outside tube end

Tube Bending

Keeping a certain length of tubing straight from fitting shoulder to the starting point of tube bend prevents the deformed section at a bend entering the fitting. This will ensure safety system.

1. Minimum straight length of tube from the starting point of tube bend to the tube end may be 3 times height of the nut

Assembly Instructions

- Step 1. Cut the tube at right angle with a reliable tube cutter and de-burr inside and outside tube end with a deburring tool.
- Step 2. Set a nut and sleeve on the tube. Make sure the sleeve and the nut are facing the fitting.
- Step 3. Lubricate fitting threads and sleeve. Insert tube end into fitting body until it is firmly seated on bottom (fitting shoulder) and hand-tighten the nut
- Step 4. Tighten nut 1-1/2 turns with a wrench by holding fitting body with a back up wrench. Marking the nut may be necessary for counting the number of turn.

Note : In case of thin wall tubing make-up, more than 1-1/2 turns may be required.

Checking up the Bite condition

To ensure pressure-tight connection, all Dk Bite type fittings must be disassembled prior to service to check up if small ridge inside the tube is completely formed around front edge of sleeve. Otherwise tighten slightly more to have it.

Sleeve may rotate on the tube that doesn't mean wrong installation. The sleeve shall be refitted once the nut is retightened.

Note : In case you see no ridge formed on the tube, this would be possibly resulted from not fully bottomed tube or not fully tightened nut. In heavy wall tubing, though you may not see the ridge, the pressure-tight seal is made as far as the sleeve firmly bites the tube and is constrained axially.

One of Dk Bite Type Fitting benefits is reusable many times. Further to check up the bite condition, you need to know how to do reassembly.

Reassembly Instructions

Fitting can be used many times. To ensure this, parts must be clean and free of defects.

Step 1. Insert the tube into fitting body until sleeve seats firmly in the fitting and hand-tighten the nut.

Step 2. Tighten the nut with a wrench by holding the fitting body with a backup wrench until a sharp rise in torque is felt. Further tighten the nut 1/4 to 1/2 turn.

Now the reassembly is complete and ready to service.

In most cases, leakage problem occurs:

1. When the tube is not fully bottomed
2. When the nut is not tightened enough
3. When the tube is of scratches or oval

If you still face a leakage problem even if you went through above 1 to 3, it may be the problem of extremely hard tube which is not suitable for bending.

Note : Steel sleeve is not supposed to be loose back and forth beyond bite point whereas Stainless sleeve could possibly move back and forth due to its more spring-like characteristics.

Safe Component Selection

The selection of component for any applications, system design must be considered to ensure safe performance.

Component function, material compatibility, component ratings, proper installation, operation and maintenance remain the sole responsibility of the system designer and the user. Dk Tech accepts no liability for any improper installation, operation and maintenance.

Note : All the information here are not for design purpose just reference only and the accuracy of information here is not liability of our company.

Ordering Information

Fittings ends and configuration are identified by symbolized letters and the series of numbers.

Example : B MC 06 - 02 R - C
 ① ② ③ ④ ⑤ ⑥

- ① DK Bite Type Fitting designated as B
- ② Name of Fittings : See products Index
- ③ Tube O.D. : See Tube and Pipe O.D. Designator
- ④ Pipe Threads : See Pipe Thread Designator
- ⑤ Pipe Thread Symbols : See Pipe Thread Symbol Designator
- ⑥ Material : See Fitting Material Designator

③ Tube and Pipe O.D. Designator

Metric Tube	O.D	4	6	8	10	12.....30.....50			
	Designation	04	06	08	10	12.....30.....50			
	Nominal Dia.	2/8	1/4	3/8	1/2	3/4	1	1-1/4	1-1/2
SCH. Pipe	O.D	10.5	13.8	17.3	21.7	27.2	34.0	42.7	48.6
	Designation	06A	08A	10A	15A	20A	25A	32A	40A

④ Pipe Thread Designator

Thread	1/8	1/4	3/8	1/2	3/4	1	1-1/4	1-1/2	2
Designation	01	02	03	04	06	08	10	12	16

⑤ Pipe Thread Symbol Designator

Type	Symbol	Specification
Taper Threads	R	JIS B 0203 (PT), ISO 7/1
	N	ANSI B1.20.1 (NPT)
Parallel Threads	G	JIS B0202 (PF), ISO 228/1

⑥ Fitting Material Designator

Fitting Material Identifier	S.S316	S.S304	C.Steel	Brass
	S	4	C	B

Custom designs

Custom designs are welcome to help our customer go round a problem. You may therefore no longer need to redesign or increase the cost of your installation by being with us next to you.

Bite Type Tube Fittings

Male Stud form and Sealing to JIS B2351

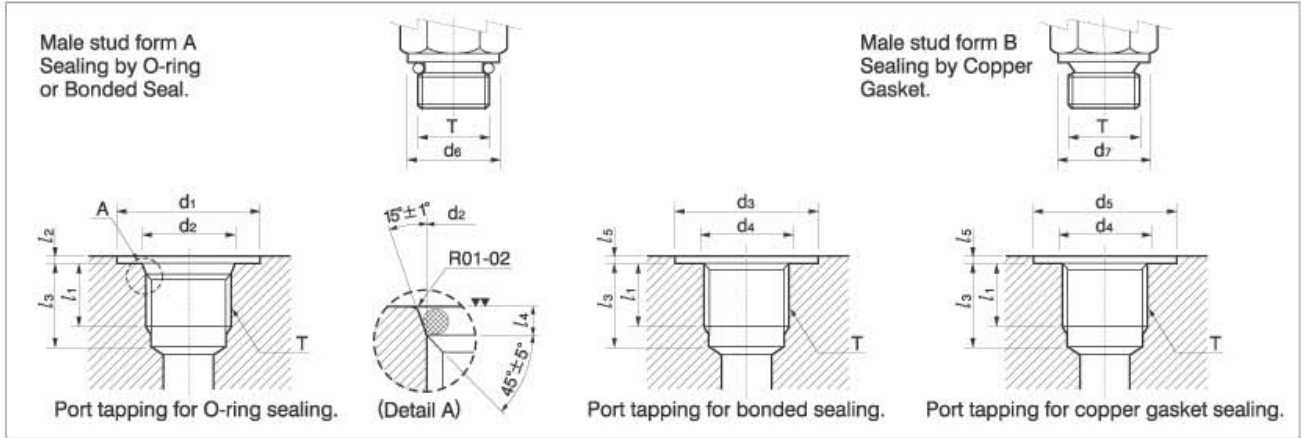

T	d ₁	d ₂ ^{+0.1 0}	d ₃ ^{+0.3 0}	Max d ₄	d ₅ ^{+0.3 0}	d ₆	d ₇	Min l ₁	Max l ₂	Min l ₃	l ₄ ^{+0.4 0}	l ₅	Suitable Seal		
													O-Ring	Bonded Seal	Copper Gasket
PF 1/8	18	11.6	17.4	9.7	18.2	14	14	10	1	15	2	1	P8	BBG-01	BCG-01
PF 1/4	24	15.6	20.9	13.1	13.1	19	18	14	1.5	20	2.5	1	P11	BBG-02	BCG-02
PF 3/8	28	18.6	24.4	16.6	16.6	22	21.5	14	2	20	2.5	1	P14	BBG-03	BCG-03
PF 1/2	34	22.6	29.4	20.9	20.9	27	25.5	17	2.5	25	2.5	1	P18	BBG-04	BCG-04
PF 3/4	45	29.8	34.9	26.4	26.4	36	31.5	19	2.5	27	3.5	1	P24	BBG-06	BCG-06
PF 1	51	35.8	41.9	33.2	33.2	41	38	22	2.5	31	3.5	1	P29	BBG-08	BCG-08
PF 1-1/4	62	44.8	50.9	41.9	41.9	50	48.5	24	2.5	33	3.5	1	P38	BBG-10	BCG-10
PF 1-1/2	68	50.8	57.4	47.8	47.8	55	53.5	25	2.5	34	3.5	1	P44	BBG-12	BCG-12
PF 2	76	67.2	69.4	59.6	59.6	75	66	29	2.5	38	3.5	1	P56	BBG-16	BCG-16

Bonded Seal

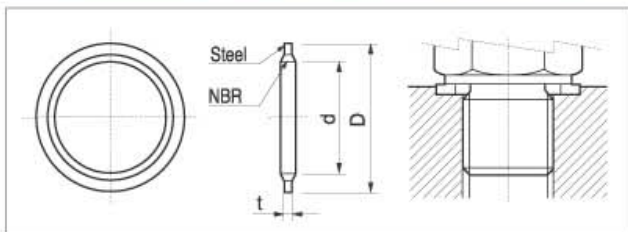

PART No.	Male Thread	d	D	t
BBG-01	PF 1/8	9.9	17	2
BBG-02	PF 1/4	13.3	20.5	2
BBG-03	PF 3/8	16.8	24	2
BBG-04	PF 1/2	21.1	29	2
BBG-06	PF 3/4	26.6	34.5	2
BBG-08	PF 1	33.4	41.5	2.3
BBG-10	PF 1-1/4	42.1	50.5	2.3
BBG-12	PF 1-1/2	48.0	57	2.3
BBG-16	PF 2	59.8	69	2.3

Copper Gasket

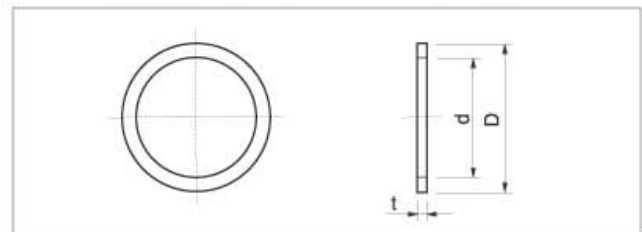

PART No.	Male Thread	d	D	t
BCG-01	PF 1/8	10	18	2
BCG-02	PF 1/4	14	22	2
BCG-03	PF 3/8	17	26	2
BCG-04	PF 1/2	22	32	2
BCG-06	PF 3/4	27	38	2
BCG-08	PF 1	34	42	2
BCG-10	PF 1-1/4	43	53	2
BCG-12	PF 1-1/2	49	60	2
BCG-16	PF 2	61	72	2

BU

Straight Union

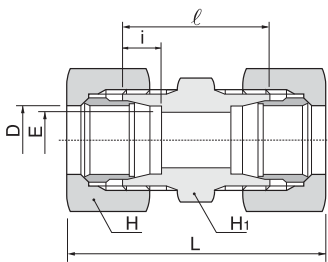

Designations	Tube O.D.		Width across flat i			l	Approx L	
	D	E	H ₁	H				
BU-06	6	4	14	14	7	30	51	
BU-08	8	6	17	17	7	31	52	
BU-10	10	8	17	19	7	31	54	
BU-12	12	10	19	22	7	31	54	
BU-15	15	12	24	27	7.5	36	61	
BU-16	16	13	27	30	7.5	36	61	
BU-18	18	14	27	32	8	36	61	
BU-20	20	17	30	36	8	38	63	
BU-22	22	18	32	36	9	38	63	
BU-25	25	20	36	41	10	39	66	
BU-28	28	22	41	46	10	43	71	
BU-30	30	25	41	46	10	43	72	
BU-32	32	26	46	50	11	44	73	
BU-35	35	28	46	55	11	44	79	
BU-38	38	32	50	60	12	46	85	
BU-40	40	32	55	60	12	55	94	
BU-42	42	34	55	60	12	55	94	
BU-06A	1/8	10.5	8	17	19	7	31	54
BU-08A	1/4	13.8	11	22	24	7.5	36	60
BU-10A	3/8	17.3	14	27	32	8	36	61
BU-15A	1/2	21.7	18	32	36	9	38	63
BU-20A	3/4	27.2	22	41	46	10	43	71
BU-25A	1	34.0	28	46	55	11	44	79
BU-32A	1-1/4	42.7	34	60	65	12	57	98
BU-40A	1-1/2	48.6	40	65	75	12	60	103

BL

Union Elbow

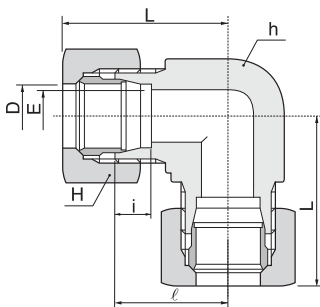

Designations	Tube O.D.		Width across flat i			l	Approx L	
	D	E	h	H				
BL-06	6	4	14	14	7	20	30.5	
BL-08	8	6	17	17	7	23	33.5	
BL-10	10	8	17	19	7	23	34.5	
BL-12	12	10	19	22	7	24	35.5	
BL-15	15	12	24	27	7.5	29	41.5	
BL-16	16	13	27	30	7.5	32	44.5	
BL-18	18	14	27	32	8	32	44.5	
BL-20	20	17	30	36	8	33	45.5	
BL-22	22	18	32	36	9	34	46.5	
BL-25	25	20	36	41	10	36	49.5	
BL-28	28	22	41	46	10	41	55	
BL-30	30	25	41	46	10	41	55.5	
BL-32	32	26	46	50	11	45	59.5	
BL-35	35	28	46	55	11	46	63.5	
BL-38	38	32	50	60	12	50	69.5	
BL-40	40	32	55	60	12	55	74.5	
BL-42	42	34	55	60	12	55	74.5	
BL-06A	1/8	10.5	8	17	19	7	23	34.5
BL-08A	1/4	13.8	11	22	24	7.5	28	40
BL-10A	3/8	17.3	14	27	32	8	32	44.5
BL-15A	1/2	21.7	18	32	36	9	34	46.5
BL-20A	3/4	27.2	22	41	46	10	41	55
BL-25A	1	34.0	28	46	55	11	46	63.5
BL-32A	1-1/4	42.7	34	60	65	12	57	77.5
BL-40A	1-1/2	48.6	40	65	75	12	62	83.5

Bite Type Tube Fittings

BT

Union Tee

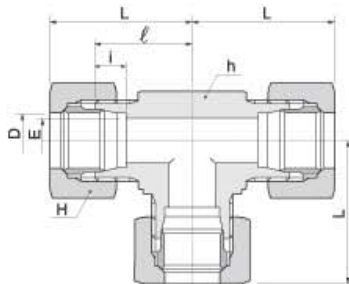

Designations	Tube O.D.		Width across flat		i	ℓ	Approx L
	D	E	h	H			
BT-06	6	4	14	14	7	20	30.5
BT-08	8	6	17	17	7	23	33.5
BT-10	10	8	17	19	7	23	34.5
BT-12	12	10	19	22	7	24	35.5
BT-15	15	12	24	27	7.5	29	41.5
BT-16	16	13	27	30	7.5	32	44.5
BT-18	18	14	27	32	8	32	44.5
BT-20	20	17	30	36	8	33	45.5
BT-22	22	18	32	36	9	34	46.5
BT-25	25	20	36	41	10	36	49.5
BT-28	28	22	41	46	10	41	55
BT-30	30	25	41	46	10	41	55.5
BT-32	32	26	46	50	11	45	59.5
BT-35	35	28	46	55	11	46	63.5
BT-38	38	32	50	60	12	50	69.5
BT-40	40	32	55	60	12	55	74.5
BT-42	42	34	55	60	12	55	74.5
BT-06A	1/8	10.5	8	17	7	23	34.5
BT-08A	1/4	13.8	11	22	7.5	28	40
BT-10A	3/8	17.3	14	27	8	32	44.5
BT-15A	1/2	21.7	18	32	9	34	46.5
BT-20A	3/4	27.2	22	41	10	41	55
BT-25A	1	34.0	28	46	11	46	63.5
BT-32A	1-1/4	42.7	34	60	12	57	77.5
BT-40A	1-1/2	48.6	40	65	12	62	83.5

BBU

Straight Bulkhead Union

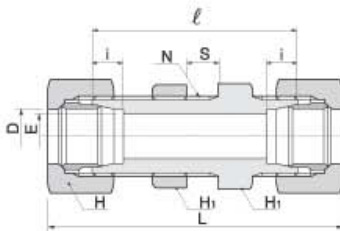

Designations	Tube O.D.		Width across flat		i	ℓ	Approx L	Panel Hole Drill Size N	Max. Panel Thickness S
	D	E	H ₁	H					
BBU-06	6	4	17	14	7	51	72	12.5	13
BBU-08	8	6	19	17	7	51	72	14.5	13
BBU-10	10	8	22	19	7	52	75	16.5	13
BBU-12	12	10	24	22	7	52	75	18.5	13
BBU-15	15	12	27	27	7.5	59	84	22.5	15
BBU-16	16	13	30	30	7.5	61	86	24.5	15
BBU-18	18	14	32	32	8	63	88	26.5	15
BBU-20	20	17	36	36	8	63	88	28.5	15
BBU-22	22	18	36	36	9	64	89	30.5	15
BBU-25	25	20	41	41	10	64	91	35.5	15
BBU-28	28	22	46	46	10	69	97	38.5	15
BBU-30	30	25	46	46	10	69	98	40.5	15
BBU-32	32	26	50	50	11	73	102	42.5	15
BBU-35	35	28	50	55	11	73	108	45.5	15
BBU-38	38	32	55	60	12	76	115	48.5	15
BBU-40	40	32	60	60	12	87	126	52.5	15
BBU-06A	1/8	10.5	8	22	7	52	75	16.5	13
BBU-08A	1/4	13.8	11	27	7.5	59	83	20.5	15
BBU-10A	3/8	17.3	14	32	8	63	88	26.5	15
BBU-15A	1/2	21.7	18	36	9	64	89	30.5	15
BBU-20A	3/4	27.2	22	46	10	69	97	38.5	15
BBU-25A	1	34.0	28	50	11	73	108	45.5	15
BBU-32A	1-1/4	42.7	34	65	12	90	131	56.5	15
BBU-40A	1-1/2	48.6	40	70	12	93	136	64.5	15

BBL

Bulkhead Elbow

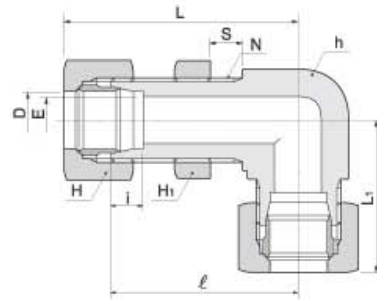

Designations	Tube O.D.		Width across flat			i	ℓ	Approx		Panel Hole Drill Size N	Max. Panel Thickness S
	D	E	h	H ₁	H			L ₁	L		
BBL-06	6	4	17	17	14	7	45	33.5	55.5	12.5	13
BBL-08	8	6	19	19	17	7	46	34.5	56.5	14.5	13
BBL-10	10	8	22	22	19	7	48	37.5	59.5	16.5	13
BBL-12	12	10	24	24	22	7	49	38.5	60.5	18.5	13
BBL-15	15	12	27	27	27	7.5	57	43.5	69.5	22.5	15
BBL-16	16	13	30	30	30	7.5	59	45.5	71.5	24.5	15
BBL-18	18	14	32	32	32	8	63	45.5	75.5	26.5	15
BBL-20	20	17	36	36	36	8	65	45.5	77.5	28.5	15
BBL-22	22	18	36	36	36	9	65	48.5	77.5	30.5	15
BBL-25	25	20	41	41	41	10	68	52.5	81.5	35.5	15
BBL-28	28	22	46	46	46	10	70	55	84	38.5	15
BBL-30	30	25	46	46	46	10	74	60.5	88.5	40.5	15

BLMC

Long Male Connector

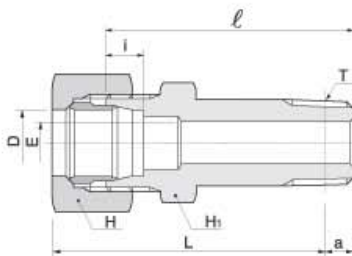

Designations	Tube O.D.		(PT)	E	Basic Gauge length a	Width across flat		i	ℓ	Approx L
	D	T				H ₁	H			
BLMC06-01R	6	1/8	4	3.97	14	14	7	63	69.5	
BLMC08-02R	8	1/4	6	6.01	17	17	7	70	74.5	
BLMC10-02R	10	1/4	7	6.01	17	19	7	71	76.5	
BLMC10-03R	10	3/8	8	6.35	19	19	7	72	77	
BLMC12-02R	12	1/4	7	6.01	19	22	7	71	76.5	
BLMC12-03R	12	3/8	9	6.35	19	22	7	72	77	
BLMC15-03R	15	3/8	9	6.35	24	27	7.5	81	87	
BLMC15-04R	15	1/2	12	8.16	24	27	7.5	86	90.5	
BLMC16-04R	16	1/2	12	8.16	27	30	7.5	86	90.5	
BLMC18-04R	18	1/2	12	8.16	27	32	8	86	90.5	
BLMC20-06R	20	3/4	16	9.53	30	36	8	92	95	
BLMC22-06R	22	3/4	16	9.53	32	36	9	93	96	
BLMC25-08R	25	1	20	10.39	36	41	10	99	102	
BLMC28-08R	28	1	22	10.39	41	46	10	104	107.5	
BLMC30-10R	30	1-1/4	25	12.70	46	46	10	109	111	
BLMC32-10R	32	1-1/4	26	12.70	46	50	11	110	112	
BLMC06A-02R	1/8	10.5	1/4	7	6.01	17	19	7	71	76.5
BLMC08A-03R	1/4	13.8	3/8	9	6.35	22	24	7.5	81	86.5
BLMC10A-03R	3/8	17.3	3/8	9	6.35	27	32	8	81	87
BLMC15A-06R	1/2	21.7	3/4	16	9.53	32	36	9	93	96
BLMC20A-08R	3/4	27.2	1	22	10.39	41	46	10	104	107.5

Bite Type Tube Fittings

BMC-R

Male Connector

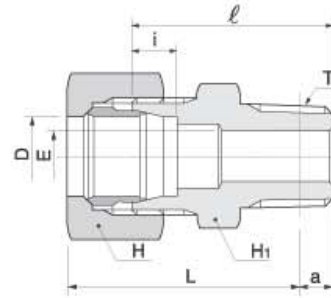
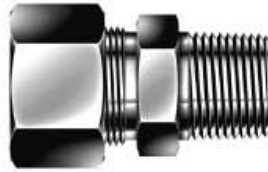

Designations	Tube O.D.		(PT)	E	Basic Gauge length a	Width across flat		i	l	Approx L
	D	T				H ₁	H			
BMC06-01R	6	1/8	4	4	3.97	14	14	7	28	34.5
BMC06-02R	6	1/4	4	4	6.01	17	14	7	33	37.5
BMC06-03R	6	3/8	4	4	6.35	19	14	7	34	38.5
BMC08-01R	8	1/8	4	4	3.97	17	17	7	29	35.5
BMC08-02R	8	1/4	6	6	6.01	17	17	7	33	37.5
BMC10-02R	10	1/4	7	7	6.01	17	19	7	33	38.5
BMC10-03R	10	3/8	8	8	6.35	19	19	7	34	39
BMC10-04R	10	1/2	8	8	8.16	22	19	7	39	42.5
BMC12-02R	12	1/4	7	7	6.01	19	22	7	33	38.5
BMC12-03R	12	3/8	9	9	6.35	19	22	7	34	39
BMC12-04R	12	1/2	10	10	8.16	24	22	7	39	42.5
BMC15-03R	15	3/8	9	9	6.35	24	27	7.5	37	43
BMC15-04R	15	1/2	12	12	8.16	24	27	7.5	41	45.5
BMC16-03R	16	3/8	9	9	6.35	27	30	7.5	37	43
BMC16-04R	16	1/2	12	12	8.16	27	30	7.5	41	45.5
BMC18-04R	18	1/2	12	12	8.16	27	32	8	41	45.5
BMC20-04R	20	1/2	12	12	8.16	30	36	8	43	47.5
BMC20-06R	20	3/4	16	16	9.53	30	36	8	45	48
BMC22-04R	22	1/2	12	12	8.16	32	36	9	43	47.5
BMC22-06R	22	3/4	16	16	9.53	32	36	9	45	48
BMC25-08R	25	1	20	20	10.39	36	41	10	49	52
BMC28-08R	28	1	22	22	10.39	41	46	10	51	54.5
BMC30-08R	30	1	22	22	10.39	41	46	10	51	55
BMC30-10R	30	1-1/4	25	25	12.70	46	46	10	55	57
BMC32-10R	32	1-1/4	26	26	12.70	46	50	11	55	57
BMC35-10R	35	1-1/4	28	28	12.70	46	55	11	55	60
BMC38-12R	38	1-1/2	32	32	12.70	50	60	12	57	64
BMC40-12R	40	1-1/2	32	32	12.70	55	60	12	62	69
BMC42-12R	42	1-1/2	34	34	12.70	55	60	12	62	69
BMC06A-01R	1/8	10.5	1/8	4	3.97	17	19	7	29	36.5
BMC06A-02R	1/8	10.5	1/4	7	6.01	17	19	7	33	38.5
BMC08A-02R	1/4	13.8	1/4	7	6.01	22	24	7.5	36	42
BMC08A-03R	1/4	13.8	3/8	9	6.35	22	24	7.5	37	42.5
BMC10A-03R	3/8	17.3	3/8	9	6.35	27	32	8	37	43
BMC10A-04R	3/8	17.3	1/2	12	8.16	27	32	8	41	45.5
BMC15A-04R	1/2	21.7	1/2	12	8.16	32	36	9	43	47.5
BMC15A-06R	1/2	21.7	3/4	16	9.53	32	36	9	45	48
BMC20A-06R	3/4	27.2	3/4	16	9.53	41	46	10	48	52.5
BMC20A-08R	3/4	27.2	1	22	10.39	41	46	10	51	54.5
BMC25A-08R	1	34.0	1	22	10.39	46	55	11	52	59
BMC25A-10R	1	34.0	1-1/4	28	12.70	46	55	11	55	60
BMC32A-10R	1-1/4	42.7	1-1/4	31	12.70	60	65	12	64	71
BMC32A-12R	1-1/4	42.7	1-1/2	34	12.70	60	65	12	64	71
BMC40A-12R	1-1/2	48.6	1-1/2	36	12.70	65	75	12	67	76
BMC40A-16R	1-1/2	48.6	2	40	15.88	65	75	12	71	76.5

BMC-G

Male Connector

Male Stud Form B
sealing by copper
gasket
See page 5

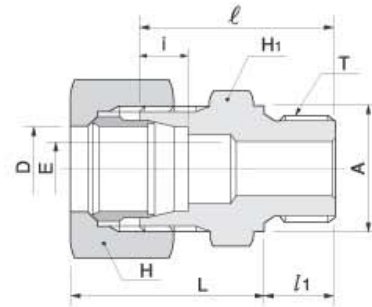

Designations	Tube O.D.		(PF) T	E	Width across flat		i	ℓ	A	l ₁	Approx L
	D				H ₁	H					
BMC06-01G	6		1/8	4	14	14	7	28	14	8	30.5
BMC06-02G	6		1/4	4	19	14	7	33	18	12	31.5
BMC08-01G	8		1/8	4	17	17	7	28	14	8	30.5
BMC08-02G	8		1/4	6	19	17	7	33	18	12	31.5
BMC10-02G	10		1/4	6	19	19	7	33	18	12	32.5
BMC10-03G	10		3/8	8	22	19	7	34	21.5	12	33.5
BMC12-02G	12		1/4	6	19	22	7	33	18	12	32.5
BMC12-03G	12		3/8	8	22	22	7	34	21.5	12	33.5
BMC12-04G	12		1/2	10	27	22	7	39	25.5	14	36.5
BMC15-03G	15		3/8	8	24	27	7.5	37	21.5	12	37.5
BMC15-04G	15		1/2	12	27	27	7.5	41	25.5	14	39.5
BMC16-04G	16		1/2	12	27	30	7.5	41	25.5	14	39.5
BMC18-04G	18		1/2	12	27	32	8	41	25.5	14	39.5
BMC20-06G	20		3/4	16	32	36	8	46	31.5	16	42.5
BMC22-04G	22		1/2	12	32	36	9	43	25.5	14	41.5
BMC22-06G	22		3/4	16	32	36	9	46	31.5	16	42.5
BMC25-06G	25		3/4	16	36	41	10	46	31.5	16	43.5
BMC25-08G	25		1	20	41	41	10	50	38	18	45.5
BMC28-08G	28		1	22	41	46	10	52	38	18	48
BMC30-08G	30		1	22	41	46	10	52	38	18	48.5
BMC30-10G	30		1-1/4	25	50	46	10	57	48.5	20	51.5
BMC32-10G	32		1-1/4	26	50	50	11	57	48.5	20	51.5
BMC35-10G	35		1-1/4	28	50	55	11	57	48.5	20	54.5
BMC38-12G	38		1-1/2	32	55	60	12	58	53.5	21	56.5
BMC40-12G	40		1-1/2	32	55	60	12	62	53.5	21	60.5
BMC42-12G	42		1-1/2	34	55	60	12	62	53.5	21	60.5
BMC06A-01G	1/8	10.5	1/8	4	17	19	7	29	14	8	32.5
BMC06A-02G	1/8	10.5	1/4	6	19	19	7	33	18	12	32.5
BMC08A-02G	1/4	13.8	1/4	6	22	24	7.5	36	18	12	36
BMC08A-03G	1/4	13.8	3/8	8	22	24	7.5	36	21.5	12	36
BMC10A-03G	3/8	17.3	3/8	8	27	32	8	38	21.5	12	38.5
BMC10A-04G	3/8	17.3	1/2	12	27	32	8	41	25.5	14	39.5
BMC15A-04G	1/2	21.7	1/2	12	32	36	9	43	25.5	14	41.5
BMC15A-06G	1/2	21.7	3/4	16	32	36	9	46	31.5	16	42.5
BMC20A-06G	3/4	27.2	3/4	16	41	46	10	50	31.5	16	48
BMC20A-08G	3/4	27.2	1	22	41	46	10	52	38	18	48
BMC25A-08G	1	34.0	1	22	46	55	11	54	38	18	53.5
BMC25A-10G	1	34.0	1-1/4	28	50	55	11	57	48.5	20	54.5
BMC32A-10G	1-1/4	42.7	1-1/4	31	60	65	12	63	48.5	20	62.5
BMC32A-12G	1-1/4	42.7	1-1/2	34	60	65	12	64	53.5	21	62.5
BMC40A-12G	1-1/2	48.6	1-1/2	36	65	75	12	65	53.5	21	65.5
BMC40A-16G	1-1/2	48.6	2	40	70	75	12	73	66	25	69.5

Bite Type Tube Fittings

BOM

Male Connector
(For O-ring)

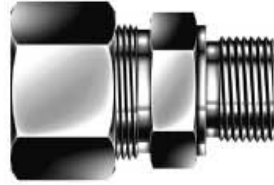

Male Stud Form A
sealing by O-ring
or Bonded seal
See page 5

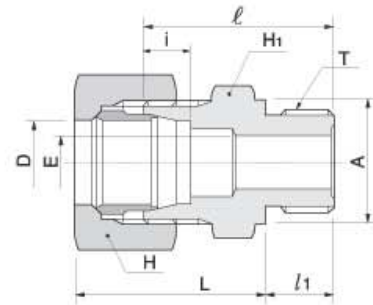

Designations	Tube O.D.		(PF) T	E	Width across flat		i	A	l ₁	l	Approx L
	D				H ₁	H					
BOM06-01G	6		1/8	4	14	14	7	14	8	28	30.5
BOM06-02G	6		1/4	4	19	14	7	19	12	33	31.5
BOM08-01G	8		1/8	4	17	17	7	14	8	28	30.5
BOM08-02G	8		1/4	6	19	17	7	19	12	33	31.5
BOM10-02G	10		1/4	6	19	19	7	19	12	33	32.5
BOM10-03G	10		3/8	8	22	19	7	22	12	34	33.5
BOM12-02G	12		1/4	6	19	22	7	19	12	33	32.5
BOM12-03G	12		3/8	8	22	22	7	22	12	34	33.5
BOM12-04G	12		1/2	10	27	22	7	27	14	39	36.5
BOM15-03G	15		3/8	8	24	27	7.5	22	12	37	37.5
BOM15-04G	15		1/2	12	27	27	7.5	27	14	41	39.5
BOM16-04G	16		1/2	12	27	30	7.5	27	14	41	39.5
BOM18-04G	18		1/2	12	27	32	8	27	14	41	39.5
BOM20-06G	20		3/4	16	36	36	8	36	16	46	42.5
BOM22-06G	22		3/4	16	36	36	9	36	16	46	42.5
BOM25-06G	25		3/4	16	36	41	10	36	16	46	43.5
BOM25-08G	25		1	20	41	41	10	41	18	50	45.5
BOM28-08G	28		1	22	41	46	10	41	18	52	48
BOM30-08G	30		1	22	41	46	10	41	18	52	48.5
BOM30-10G	30		1-1/4	25	50	46	10	50	20	57	51.5
BOM32-10G	32		1-1/4	26	50	50	11	50	20	57	51.5
BOM35-10G	35		1-1/4	28	50	55	11	50	20	57	54.5
BOM38-12G	38		1-1/2	32	55	60	12	55	21	58	56.5
BOM40-12G	40		1-1/2	32	55	60	12	55	21	62	60.5
BOM42-12G	42		1-1/2	34	55	60	12	55	21	62	60.5
BOM06A-01G	1/8	10.5	1/8	4	17	19	7	14	8	29	32.5
BOM06A-02G	1/8	10.5	1/4	6	19	19	7	19	12	33	32.5
BOM08A-02G	1/4	13.8	1/4	6	22	24	7.5	19	12	36	36
BOM08A-03G	1/4	13.8	3/8	8	22	24	7.5	22	12	36	36
BOM10A-03G	3/8	17.3	3/8	8	27	32	8	22	12	38	38.5
BOM10A-04G	3/8	17.3	1/2	12	27	32	8	27	14	41	39.5
BOM15A-04G	1/2	21.7	1/2	12	32	36	9	27	14	43	41.5
BOM15A-06G	1/2	21.7	3/4	16	36	36	9	36	16	46	42.5
BOM20A-06G	3/4	27.2	3/4	16	41	46	10	36	16	50	48
BOM20A-08G	3/4	27.2	1	22	41	46	10	41	18	52	48
BOM25A-08G	1	34.0	1	22	46	55	11	41	18	54	53.5
BOM25A-10G	1	34.0	1-1/4	28	50	55	11	50	20	57	54.5
BOM32A-10G	1-1/4	42.7	1-1/4	31	60	65	12	50	20	63	62.5
BOM32A-12G	1-1/4	42.7	1-1/2	34	60	65	12	55	21	64	62.5
BOM40A-12G	1-1/2	48.6	1-1/2	36	65	75	12	55	21	65	65.5
BOM40A-16G	1-1/2	48.6	2	40	75	75	12	75	25	73	69.5

BLM

Male Elbow

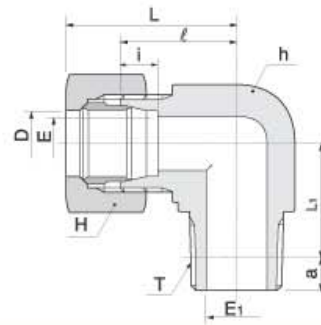

Designations	Tube O.D.		(PT) T	E	E ₁	Basic Gauge length a	Width across flat		i	ℓ	Approx	
	D						h	H			L	L ₁
BLM06-01R	6		1/8	4	4	3.97	14	14	7	20	30.5	14
BLM06-02R	6		1/4	4	7	6.01	17	14	7	23	33.5	17
BLM08-01R	8		1/8	6	4	3.97	17	17	7	23	33.5	16
BLM08-02R	8		1/4	6	7	6.01	17	17	7	23	33.5	18
BLM10-02R	10		1/4	8	7	6.01	17	19	7	23	34.5	19
BLM10-03R	10		3/8	8	9	6.35	19	19	7	24	35.5	19.5
BLM10-04R	10		1/2	8	12	8.16	24	19	7	29	40.5	26
BLM12-02R	12		1/4	10	7	6.01	19	22	7	24	35.5	20
BLM12-03R	12		3/8	10	9	6.35	19	22	7	24	35.5	20.5
BLM12-04R	12		1/2	10	12	8.16	24	22	7	29	40.5	26
BLM15-03R	15		3/8	12	9	6.35	24	27	7.5	29	41.5	23.5
BLM15-04R	15		1/2	12	12	8.16	24	27	7.5	29	41.5	26
BLM16-03R	16		3/8	13	9	6.35	27	30	7.5	32	44.5	25.5
BLM16-04R	16		1/2	13	12	8.16	27	30	7.5	32	44.5	27
BLM18-03R	18		3/8	14	9	6.35	27	32	8	32	44.5	27.5
BLM18-04R	18		1/2	14	12	8.16	27	32	8	32	44.5	30
BLM20-04R	20		1/2	17	12	8.16	30	36	8	33	45.5	32
BLM20-06R	20		3/4	17	16	9.53	30	36	8	33	45.5	30.5
BLM22-04R	22		1/2	18	12	8.16	32	36	9	34	46.5	32
BLM22-06R	22		3/4	18	16	9.53	32	36	9	34	46.5	32.5
BLM25-06R	25		3/4	20	16	9.53	36	41	10	36	49.5	33.5
BLM25-08R	25		1	20	22	10.39	36	41	10	36	49.5	35.5
BLM28-06R	28		3/4	22	16	9.53	41	46	10	41	55	37.5
BLM28-08R	28		1	22	22	10.39	41	46	10	41	55	39.5
BLM30-08R	30		1	25	22	10.39	41	46	10	41	55.5	39.5
BLM30-10R	30		1-1/4	25	31	12.70	46	46	10	46	60.5	42.5
BLM32-10R	32		1-1/4	26	31	12.70	46	50	11	46	60.5	43.5
BLM35-10R	35		1-1/4	28	31	12.70	46	55	11	46	63.5	45.5
BLM38-12R	38		1-1/2	32	36	12.70	50	60	12	50	69.5	48.5
BLM40-12R	40		1-1/2	32	36	12.70	55	60	12	55	74.5	49.5
BLM42-12R	42		1-1/2	34	36	12.70	55	60	12	55	74.5	49.5
BLM06A-01R	1/8	10.5	1/8	8	4	3.97	17	19	7	23	34.5	17
BLM06A-02R	1/8	10.5	1/4	8	7	6.01	17	19	7	23	34.5	19
BLM08A-02R	1/4	13.8	1/4	11	7	6.01	22	24	7.5	28	40	22
BLM08A-03R	1/4	13.8	3/8	11	9	6.35	22	24	7.5	28	40	22.5
BLM10A-03R	3/8	17.3	3/8	14	9	6.35	27	32	8	32	44.5	27.5
BLM10A-04R	3/8	17.3	1/2	14	12	8.16	27	32	8	32	44.5	30
BLM15A-04R	1/2	21.7	1/2	18	12	8.16	32	36	9	34	46.5	32
BLM15A-06R	1/2	21.7	3/4	18	16	9.53	32	36	9	34	46.5	32.5
BLM20A-06R	3/4	27.2	3/4	22	16	9.53	41	46	10	41	55	37.5
BLM20A-08R	3/4	27.2	1	22	22	10.39	41	46	10	41	55	39.5
BLM25A-08R	1	34.0	1	28	22	10.39	46	55	11	46	63.5	44.5
BLM25A-10R	1	34.0	1-1/4	28	31	12.70	46	55	11	46	63.5	44.5
BLM32A-10R	1-1/4	42.7	1-1/4	34	31	12.70	60	65	12	57	77.5	51.5
BLM32A-12R	1-1/4	42.7	1-1/2	34	36	12.70	60	75	12	57	77.5	51.5
BLM40A-12R	1-1/2	48.6	1-1/2	40	36	12.70	65	75	12	62	83.5	57.5
BLM40A-16R	1-1/2	48.6	2	40	46	15.88	65	75	12	62	83.5	58

Bite Type Tube Fittings

BLLM

Long Male Elbow

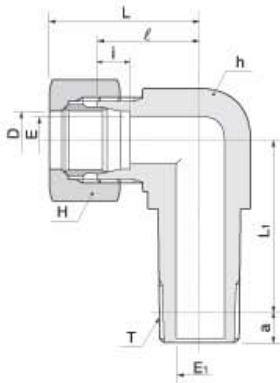

Designations	Tube O.D. (PT)		E	E ₁	Basic Gauge length a	Width across flat			i	ℓ	Approx	
	D	T				h	H	H			L	L ₁
BLLM06-01R	6	1/8	4	4	3.97	14	14	7	20	30.5	36	
BLLM08-02R	8	1/4	6	7	6.01	17	17	7	23	33.5	43	
BLLM10-02R	10	1/4	8	7	6.01	17	19	7	23	34.5	46	
BLLM12-02R	12	1/4	10	7	6.01	19	22	7	24	35.5	52	
BLLM12-03R	12	3/8	10	9	6.35	19	22	7	24	35.5	53	
BLLM15-03R	15	3/8	12	9	6.35	22	27	7.5	29	41.5	61.5	
BLLM15-04R	15	1/2	12	12	8.16	24	27	7.5	29	41.5	67	
BLLM16-04R	16	1/2	13	12	8.16	24	30	7.5	32	44.5	70	
BLLM18-04R	18	1/2	14	12	8.16	27	32	8	32	44.5	77	
BLLM20-06R	20	3/4	17	16	9.53	30	36	8	33	45.5	82.5	
BLLM22-06R	22	3/4	18	16	9.53	32	36	9	34	46.5	83.5	
BLLM25-06R	25	3/4	20	16	9.53	36	41	10	36	49.5	90.5	
BLLM25-08R	25	1	20	22	10.39	36	41	10	36	49.5	91.5	
BLLM28-08R	28	1	22	22	10.39	41	46	10	41	55	104.5	
BLLM30-10R	30	1-1/4	25	31	12.70	46	46	10	46	60.5	104.5	
BLLM32-10R	32	1-1/4	26	31	12.70	46	50	11	46	60.5	104.5	
BLLM35-10R	35	1-1/4	28	31	12.70	46	55	11	46	63.5	121.5	

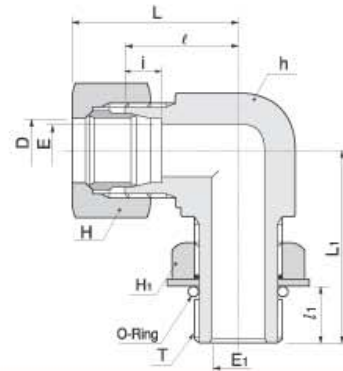

BOLM

O-Seal Male Elbow

Designations	Tube O.D. (PF)		E	E ₁	Width across flat			i	l ₁	ℓ	Approx	
	D	T			h	H ₁	H				L ₁	L
BOLM06-01G	6	1/8	4	4	14	14	14	7	10	20	30	30.5
BOLM08-02G	8	1/4	6	7	17	19	17	7	12	23	34	33.5
BOLM10-02G	10	1/4	8	7	17	19	19	7	12	23	35	34.5
BOLM12-02G	12	1/4	10	7	19	19	22	7	12	24	36	35.5
BOLM12-03G	12	3/8	10	9	19	22	22	7	12	24	36	35.5
BOLM12-04G	12	1/2	10	12	24	27	22	7	16	24	46	35.5
BOLM15-03G	15	3/8	12	9	24	22	27	7.5	12	29	40	41.5
BOLM15-04G	15	1/2	12	12	24	27	27	7.5	16	29	46	41.5
BOLM16-04G	16	1/2	13	12	24	27	30	7.5	16	32	46	44.5
BOLM18-04G	18	1/2	14	12	30	27	32	8	16	32	52	44.5
BOLM20-06G	20	3/4	17	16	30	36	36	8	17	33	52	45.5
BOLM22-06G	22	3/4	18	16	32	36	36	9	17	34	52	46.5
BOLM25-06G	25	3/4	20	16	36	36	41	10	17	36	60	49.5
BOLM25-08G	25	1	20	22	36	41	41	10	21	36	62	49.5
BOLM28-08G	28	1	22	22	41	41	46	10	21	41	62	55
BOLM30-08G	30	1	25	22	41	41	46	10	21	41	66	55.5
BOLM30-10G	30	1-1/4	25	31	41	50	46	10	21	44	66	58.5
BOLM32-10G	32	1-1/4	26	31	46	50	50	11	21	46	66	60.5
BOLM35-10G	35	1-1/4	28	31	46	50	55	11	21	46	66	63.5
BOLM38-12G	38	1-1/2	32	36	50	55	60	12	21	50	73	69.5

BSLM

Banjo Elbow

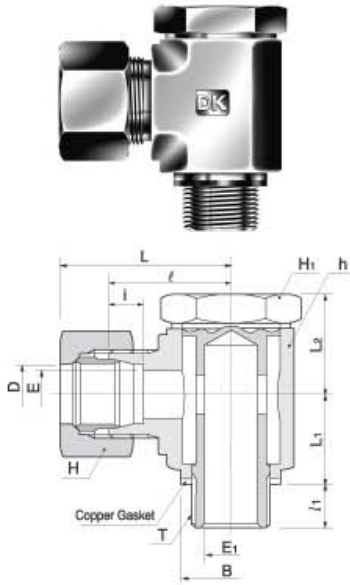

Designations	Tube O.D.		(PT)	E ₁	E	Width across flat			i	l ₁	ℓ	Approx			B
	D	T				h	H ₁	H				L ₁	L ₂	L	
BSLM06-01G	6	1/8	4	4	17	17	14	7	8	23	13	14	33.5	14	
BSLM08-02G	8	1/4	7	6	22	22	17	7	12	25	16	17	35.5	18	
BSLM10-02G	10	1/4	7	8	22	22	19	7	12	25	16	17	36.5	18	
BSLM12-03G	12	3/8	9	10	27	27	22	7	12	29	19	22	40.5	21.5	
BSLM15-04G	15	1/2	12	12	36	30	27	7.5	14	36	24	28	48.5	25.5	
BSLM16-04G	16	1/2	12	13	36	30	30	7.5	14	36	24	28	48.5	25.5	
BSLM18-04G	18	1/2	12	14	36	30	32	8	14	36	24	28	48.5	25.5	
BSLM20-06G	20	3/4	16	17	41	41	36	8	16	38	28	32	50.5	31.5	
BSLM22-06G	22	3/4	16	18	42	41	36	9	16	38	28	32	50.5	31.5	
BSLM25-08G	25	1	22	20	50	50	41	10	18	42	37	38	55.5	38	
BSLM28-08G	28	1	22	22	50	50	46	10	18	42	37	38	56	38	
BSLM06A-02G	1/8	10.5	1/4	7	8	22	22	19	7	12	25	16	17	36.5	18
BSLM08A-03G	1/4	13.8	3/8	9	11	27	27	24	7.5	12	29	19	22	41	21.5
BSLM10A-04G	3/8	17.3	1/2	12	14	36	30	32	8	14	36	24	28	48.5	25.5
BSLM15A-06G	1/2	21.7	3/4	16	18	41	41	36	9	16	38	28	32	50.5	31.5
BSLM20A-08G	3/4	27.2	1	22	22	50	50	46	10	18	42	37	38	56	38

BBTM

Male Branch Tee

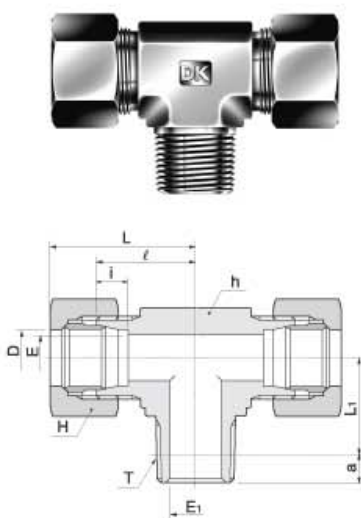

Designations	Tube O.D.		(PT)	E	E ₁	Basic Gauge length a	Width across flat		i	ℓ	Approx	
	D	T					h	H			L	L ₁
BBTM06-01R	6	1/8	4	4	3.97	14	14	7	20	30.5	14	
BBTM06-02R	6	1/4	4	7	6.01	17	14	7	23	33.5	17	
BBTM08-01R	8	1/8	6	4	3.97	17	17	7	23	33.5	16	
BBTM08-02R	8	1/4	6	7	6.01	17	17	7	23	33.5	18	
BBTM10-02R	10	1/4	8	7	6.01	17	19	7	23	34.5	19	
BBTM10-03R	10	3/8	8	9	6.35	19	19	7	24	35.5	19.5	
BBTM12-02R	12	1/4	10	7	6.01	19	22	7	24	35.5	18	
BBTM12-03R	12	3/8	10	9	6.35	19	22	7	24	35.5	20.5	
BBTM15-03R	15	3/8	12	9	6.35	24	27	7.5	29	41.5	23.5	
BBTM15-04R	15	1/2	12	12	8.16	24	27	7.5	29	41.5	26	
BBTM16-04R	16	1/2	13	12	8.16	27	30	7.5	32	44.5	27	
BBTM18-04R	18	1/2	14	12	8.16	27	32	8	32	44.5	30	
BBTM20-06R	20	3/4	17	16	9.53	30	36	8	33	45.5	30.5	
BBTM22-06R	22	3/4	18	16	9.53	32	36	9	34	46.5	32.5	
BBTM25-06R	25	3/4	20	16	9.53	36	41	10	36	49.5	33.5	
BBTM25-08R	25	1	20	22	10.39	36	41	10	36	49.5	35.5	
BBTM28-08R	28	1	22	22	10.39	41	46	10	41	55	39.5	
BBTM30-08R	30	1	25	22	10.39	41	46	10	41	55.5	39.5	
BBTM30-10R	30	1-1/4	25	31	12.70	46	46	10	46	60.5	42.5	
BBTM32-10R	32	1-1/4	26	31	12.70	46	50	11	46	60.5	43.5	
BBTM35-10R	35	1-1/4	28	31	12.70	46	55	11	46	63.5	45.5	
BBTM38-12R	38	1-1/2	32	36	12.70	50	60	12	50	69.5	48.5	
BBTM40-12R	40	1-1/2	32	36	12.70	55	60	12	55	74.5	49.5	
BBTM06A-02R	1/8	10.5	1/4	8	7	6.01	17	19	7	23	34.5	19
BBTM08A-03R	1/4	13.8	3/8	11	9	3.35	22	24	7.5	28	40	22.5
BBTM10A-04R	3/8	17.3	1/2	14	12	8.16	27	32	8	32	44.5	30
BBTM15A-06R	1/2	21.7	3/4	18	16	9.53	32	36	9	34	46.5	32.5
BBTM20A-08R	3/4	27.2	1	22	22	10.39	41	46	10	41	55	39.5
BBTM25A-10R	1	34.0	1-1/4	28	31	12.70	46	55	11	46	63.5	45.5
BBTM32A-12R	1-1/4	42.7	1-1/2	34	36	12.70	60	65	12	57	77.5	51.5
BBTM40A-16R	1-1/2	48.6	2	40	46	15.88	65	75	12	62	83.5	58

Bite Type Tube Fittings

BRTM

Male Run Tee

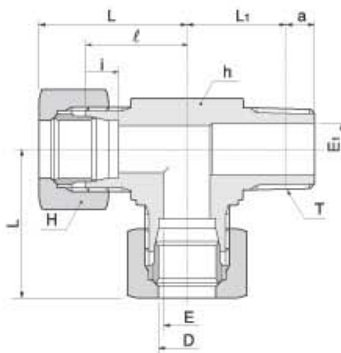

Designations	Tube O.D. (PT)		E	E ₁	Basic Gauge length a	Width across flat		i	ℓ	Approx		
	D	T				h	H			L	L ₁	
BRTM06-01R	6	1/8	4	4	3.97	14	14	7	20	30.5	14	
BRTM06-02R	6	1/4	4	7	6.01	17	14	7	23	33.5	17	
BRTM08-01R	8	1/8	6	4	3.97	17	17	7	23	33.5	16	
BRTM08-02R	8	1/4	6	7	6.01	17	17	7	23	33.5	18	
BRTM10-02R	10	1/4	8	7	6.01	17	19	7	23	34.5	19	
BRTM10-03R	10	3/8	8	9	6.35	19	19	7	24	35.5	19.5	
BRTM12-02R	12	1/4	10	7	6.01	19	22	7	24	35.5	18	
BRTM12-03R	12	3/8	10	9	6.35	19	22	7	24	35.5	20.5	
BRTM15-03R	15	3/8	12	9	6.35	24	27	7.5	29	41.5	23.5	
BRTM15-04R	15	1/2	12	12	8.16	24	27	7.5	29	41.5	26	
BRTM16-04R	16	1/2	13	12	8.16	27	30	7.5	32	44.5	27	
BRTM18-04R	18	1/2	14	12	8.16	27	32	8	32	44.5	30	
BRTM20-06R	20	3/4	17	16	9.53	30	36	8	33	45.5	30.5	
BRTM22-06R	22	3/4	18	16	9.53	32	36	9	34	46.5	32.5	
BRTM25-06R	25	3/4	20	16	9.53	36	41	10	36	49.5	33.5	
BRTM25-08R	25	1	20	22	10.39	36	41	10	36	49.5	35.5	
BRTM28-08R	28	1	22	22	10.39	41	46	10	41	55	39.5	
BRTM30-08R	30	1	25	22	10.39	41	46	10	41	55.5	39.5	
BRTM30-10R	30	1-1/4	25	31	12.70	46	46	10	46	60.5	42.5	
BRTM32-10R	32	1-1/4	26	31	12.70	46	50	11	46	60.5	43.5	
BRTM35-10R	35	1-1/4	28	31	12.70	46	55	11	46	63.5	45.5	
BRTM38-12R	38	1-1/2	32	36	12.70	50	60	12	50	69.5	48.5	
BRTM40-12R	40	1-1/2	32	36	12.70	55	60	12	55	74.5	49.5	
BRTM06A-02R	1/8	10.5	1/4	8	7	6.01	17	19	7	23	34.5	19
BRTM08A-03R	1/4	13.8	3/8	11	9	3.35	22	24	7.5	28	40	22.5
BRTM10A-04R	3/8	17.3	1/2	14	12	8.16	27	32	8	32	44.5	30
BRTM15A-06R	1/2	21.7	3/4	18	16	9.53	32	36	9	34	46.5	32.5
BRTM20A-08R	3/4	27.2	1	22	22	10.39	41	46	10	41	55	39.5
BRTM25A-10R	1	34.0	1-1/4	28	31	12.70	46	55	11	46	63.5	45.5
BRTM32A-12R	1-1/4	42.7	1-1/2	34	36	12.70	60	65	12	57	77.5	51.5
BRTM40A-16R	1-1/2	48.6	2	40	46	15.88	65	75	12	62	83.5	58

BBFC

Bulkhead Female Connector

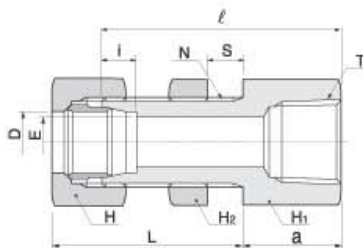
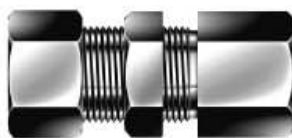

Designations	Tube O.D. (PT)		E	Width across flat			i	ℓ	a	Approx L	Panel Hole	Max. Panel
	D	T		H ₁	H ₂	H					Drill Size N	Thickness S
BBFC06-01R	6	1/8	4	17	17	14	7	45	13	42.5	12.5	13
BBFC08-02R	8	1/4	6	19	19	17	7	50	18	42.5	14.5	13
BBFC10-02R	10	1/4	8	19	22	19	7	50	18	43.5	16.5	13
BBFC10-03R	10	3/8	8	24	22	19	7	52	20	43.5	16.5	13
BBFC12-02R	12	1/4	10	22	24	22	7	50	18	43.5	18.5	13
BBFC12-03R	12	3/8	10	24	24	22	7	52	20	43.5	18.5	13
BBFC15-03R	15	3/8	12	27	27	27	7.5	57	20	49.5	22.5	15
BBFC15-04R	15	1/2	12	30	27	27	7.5	62	25	49.5	22.5	15
BBFC16-04R	16	1/2	13	30	30	30	7.5	62	25	49.5	24.5	15
BBFC18-04R	18	1/2	14	30	32	32	8	64	25	51.5	26.5	15
BBFC20-06R	20	3/4	17	36	36	36	8	66	27	51.5	28.5	15
BBFC22-06R	22	3/4	18	36	36	36	9	66	27	51.5	30.5	15
BBFC25-08R	25	1	20	46	41	41	10	70	31	52.5	35.5	15
BBFC28-08R	28	1	22	46	46	46	10	72	31	55	38.5	15
BBFC30-08R	30	1	25	46	46	46	10	72	31	55.5	40.5	15
BBFC32-10R	32	1-1/4	26	55	46	50	11	78	35	57.5	42.5	15

BFC

Female Connector

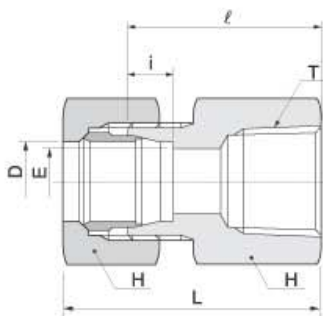
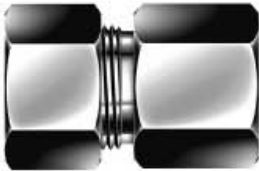

Designations	Tube O.D.		(PT)	E	Width across flat		i	ℓ	Approx L
	D	T			H ₁	H			
BFC06-01R	6	1/8	4	17	14	7	25	35.5	
BFC08-02R	8	1/4	6	19	17	7	30	40.5	
BFC10-02R	10	1/4	8	19	19	7	30	41.5	
BFC10-03R	10	3/8	8	24	19	7	32	43.5	
BFC12-02R	12	1/4	10	19	22	7	30	41.5	
BFC12-03R	12	3/8	10	24	22	7	32	43.5	
BFC15-03R	15	1/2	12	24	27	7.5	34	46.5	
BFC15-04R	15	1/2	12	30	27	7.5	39	51.5	
BFC16-04R	16	1/2	13	30	30	7.5	39	51.5	
BFC18-04R	18	1/2	14	30	32	8	39	51.5	
BFC20-06R	20	3/4	17	36	36	8	41	53.5	
BFC22-06R	22	3/4	18	36	36	9	41	53.5	
BFC25-06R	25	3/4	20	36	41	10	41	54.5	
BFC25-08R	25	1	20	46	41	10	45	58.5	
BFC28-08R	28	1	22	46	46	10	47	61	
BFC30-08R	30	1	25	46	46	10	47	61.5	
BFC30-10R	30	1-1/4	25	55	46	10	51	65.5	
BFC32-10R	32	1-1/4	26	55	50	11	51	65.5	
BFC35-10R	35	1-1/4	28	55	55	11	51	68.5	
BFC38-12R	38	1-1/2	32	65	60	12	51	70.5	
BFC40-12R	40	1-1/2	32	65	60	12	55	74.5	
BFC42-12R	42	1-1/2	34	65	60	12	55	74.5	
BFC06A-02R	1/8	10.5	1/4	8	19	19	7	30	41.5
BFC08A-03R	1/4	13.8	3/8	11	24	24	7.5	34	46
BFC10A-04R	3/8	17.3	1/2	14	30	32	8	39	51.5
BFC15A-06R	1/2	21.7	3/4	18	36	36	9	41	53.5
BFC20A-08R	3/4	27.2	1	22	46	46	10	47	61
BFC25A-10R	1	34.0	1-1/4	28	55	55	11	51	68.5
BFC32A-12R	1-1/4	42.7	1-1/2	34	65	65	12	55	78.5
BFC40A-16R	1-1/2	48.6	2	40	80	75	12	60	81.5

BGC

Gauge Connector

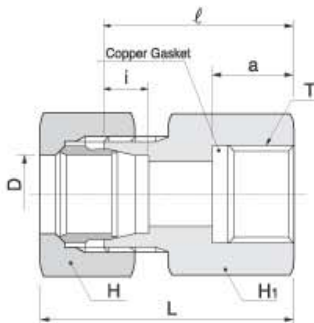

Designations	Tube O.D.		(PT)	a	Width across flat		i	ℓ	Approx L	Gasket Part No
	D	T			H ₁	H				
BGC06-02G	6	1/4	14	19	14	7	32	42.5	BGG-02	
BGC06-03G	6	3/8	15	24	14	7	34	44.5	BGG-03	
BGC06-04G	6	1/2	16	30	14	7	36	46.5	BGG-04	
BGC08-02G	8	1/4	14	19	17	7	32	42.5	BGG-02	
BGC08-03G	8	3/8	15	24	17	7	34	44.5	BGG-03	
BGC08-04G	8	1/2	16	30	17	7	36	46.5	BGG-04	
BGC10-02G	10	1/4	14	19	19	7	32	43.5	BGG-02	
BGC10-03G	10	3/8	15	24	19	7	34	45.5	BGG-03	
BGC10-04G	10	1/2	16	30	19	7	36	47.5	BGG-04	
BGC12-02G	12	1/4	14	19	22	7	32	43.5	BGG-02	
BGC12-03G	12	3/8	15	24	22	7	34	45.5	BGG-03	
BGC12-04G	12	1/2	16	30	22	7	36	47.5	BGG-04	

Bite Type Tube Fittings

BLF

Female Elbow

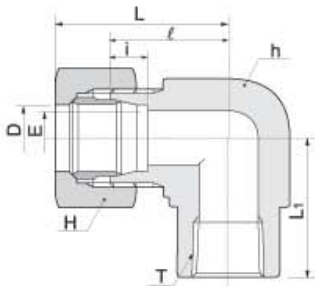

Designations	Tube O.D.		E	Width across flat		i	ℓ	Approx	
	D	T		h	H			L ₁	L
BLF08-02R	8	1/4	6	19	17	7	24	24	34.5
BLF10-02R	10	1/4	8	19	19	7	24	24	35.5
BLF12-02R	12	1/4	10	19	22	7	24	24	35.5
BLF12-03R	12	3/8	10	24	22	7	29	29	40.5
BLF15-03R	15	3/8	12	24	27	7.5	29	29	41.5
BLF15-04R	15	1/2	12	30	27	7.5	33	33	45.5
BLF16-04R	16	1/2	13	30	30	7.5	33	33	45.5
BLF18-04R	18	1/2	14	30	32	8	33	33	45.5
BLF20-06R	20	3/4	17	36	36	8	36	36	48.5
BLF22-06R	22	3/4	18	36	36	9	36	36	48.5
BLF25-06R	25	3/4	20	36	41	10	36	36	49.5
BLF25-08R	25	1	20	46	41	10	46	46	59.5
BLF28-08R	28	1	22	46	46	10	46	46	60
BLF30-10R	30	1-1/4	25	55	46	10	55	55	69.5
BLF32-10R	32	1-1/4	26	55	50	11	55	55	69.5
BLF35-10R	35	1-1/4	28	55	55	11	55	55	72.5

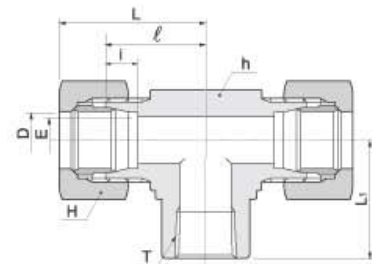

BBTF

Female Branch Tee

Designations	Tube O.D.		E	Width across flat		i	ℓ	Approx	
	D	T		h	H			L	L ₁
BBTF06-01R	6	1/8	4	17	14	7	23	34.5	24
BBTF08-02R	8	1/4	6	19	17	7	24	34.5	24
BBTF10-02R	10	1/4	8	19	19	7	24	35.5	24
BBTF12-02R	12	1/4	10	19	22	7	24	35.5	24
BBTF12-03R	12	3/8	10	24	22	7	29	40.5	29
BBTF15-03R	15	3/8	12	24	27	7.5	29	41.5	29
BBTF15-04R	15	1/2	12	30	27	7.5	33	45.5	33
BBTF16-04R	16	1/2	13	30	30	7.5	33	45.5	33
BBTF18-04R	18	1/2	14	30	32	8	33	45.5	33
BBTF20-06R	20	3/4	17	36	36	8	36	48.5	36
BBTF22-06R	22	3/4	18	36	36	9	36	48.5	36
BBTF25-06R	25	3/4	20	36	41	10	36	49.5	36
BBTF25-08R	25	1	20	46	41	10	46	59.5	46
BBTF28-08R	28	1	22	46	46	10	46	60	46
BBTF30-08R	30	1	25	46	46	10	46	60.5	46
BBTF30-10R	30	1-1/4	25	55	46	10	55	69.5	55
BBTF32-10R	32	1-1/4	26	55	50	11	55	69.5	55
BBTF35-10R	35	1-1/4	28	55	55	11	55	72.5	55
BBTF06A-02R	1/8	10.5	1/4	8	19	7	24	35.5	24
BBTF08A-03R	1/4	13.8	3/8	11	24	7.5	29	41	29
BBTF10A-04R	3/8	17.3	1/2	14	30	8	33	45.5	33
BBTF15A-06R	1/2	21.7	3/4	18	36	9	36	48.5	36
BBTF20A-08R	3/4	27.2	1	22	46	10	46	60	46
BBTF25A-10R	1	34.0	1-1/4	28	55	11	55	72.5	55

BRTF

Female Run Tee

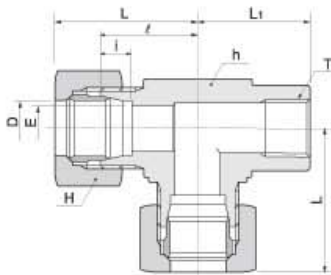

Designations	Tube O.D.		(PT)	E	Width across flat		i	ℓ	Approx	
	D	T			h	H			L	L ₁
BRTF08-02R	8	1/4	6	19	17	7	24	34.5	24	
BRTF10-02R	10	1/4	8	19	19	7	24	35.5	24	
BRTF12-02R	12	1/4	10	19	22	7	24	35.5	24	
BRTF12-03R	12	3/8	10	24	22	7	29	40.5	29	
BRTF15-03R	15	3/8	12	24	27	7.5	29	41.5	29	
BRTF15-04R	15	1/2	12	30	27	7.5	33	45.5	33	
BRTF16-04R	16	1/2	13	30	30	7.5	33	45.5	33	
BRTF18-04R	18	1/2	14	30	32	8	33	45.5	33	
BRTF20-06R	20	3/4	17	36	36	8	36	48.5	36	
BRTF22-06R	22	3/4	18	36	36	9	36	48.5	36	
BRTF25-06R	25	3/4	20	36	41	10	36	49.5	36	
BRTF25-08R	25	1	20	46	41	10	46	59.5	46	
BRTF28-08R	28	1	22	46	46	10	46	60	46	
BRTF30-08R	30	1	25	46	46	10	46	60.5	46	
BRTF30-10R	30	1-1/4	25	55	46	10	55	69.5	55	
BRTF32-10R	32	1-1/4	26	55	50	11	55	69.5	55	
BRTF35-10R	35	1-1/4	28	55	55	11	55	72.5	55	
BRTF06A-02R	1/8	10.5	1/4	8	19	19	7	24	35.5	24
BRTF08A-03R	1/4	13.8	3/8	11	24	24	7.5	29	41	29
BRTF10A-04R	3/8	17.3	1/2	14	30	32	8	33	45.5	33
BRTF15A-06R	1/2	21.7	3/4	18	36	36	9	36	48.5	36
BRTF20A-08R	3/4	27.2	1	22	46	46	10	46	60	46
BRTF25A-10R	1	34.0	1-1/4	28	55	55	11	55	72.5	55

BJ

Presetting Jig

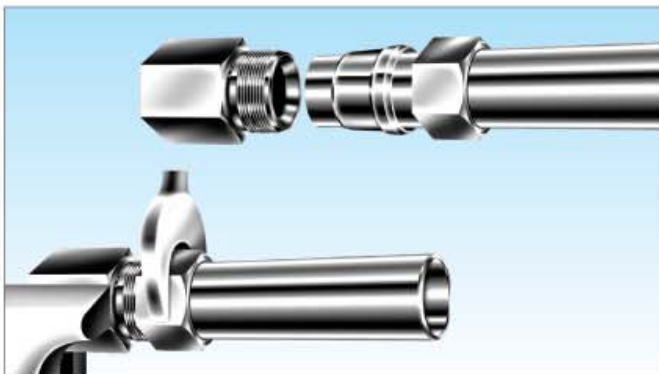
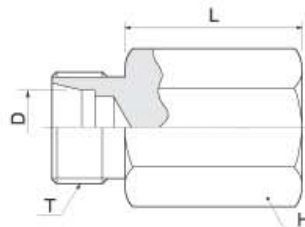

When assembling Bite type fitting in close corner or in cabinet it may be advantageous to use this jig.

It allows the presetting of sleeve on to the tube in a more open or safe area.

After using this jig, follow the reassembly instruction.

Tubing may occasionally stick in the jig after pull-up. In this case, remove the tube by gently rocking back and forth. Do not rock up and down or turn the tube as this may damage sealing surfaces of fitting.

Designations	Tube O.D.		L	H	h
	D	T			
BJ-06	6	40	17	M12 x 1.5	
BJ-08	8	40	17	M14 x 1.5	
BJ-10	10	40	17	M16 x 1.5	
BJ-12	12	40	27	M18 x 1.5	
BJ-15	15	40	27	M22 x 1.5	
BJ-16	16	40	27	M24 x 1.5	
BJ-18	18	40	27	M26 x 1.5	
BJ-20	20	40	41	M28 x 1.5	
BJ-22	22	40	41	M30 x 1.5	
BJ-25	25	40	41	M35 x 1.5	
BJ-28	28	40	41	M38 x 1.5	
BJ-30	30	40	41	M40 x 1.5	
BJ-32	32	40	55	M42 x 1.5	
BJ-35	35	40	55	M45 x 1.5	
BJ-38	38	50	55	M48 x 1.5	
BJ-40	40	50	55	M52 x 2.0	
BJ-42	42	50	55	M52 x 2.0	
BJ-06A	1/8	10.5	40	17	M16 x 1.5
BJ-08A	1/4	13.8	40	27	M20 x 1.5
BJ-10A	3/8	17.3	40	27	M26 x 1.5
BJ-15A	1/2	21.7	40	41	M30 x 1.5
BJ-20A	3/4	27.2	40	41	M38 x 1.5
BJ-25A	1	34.0	40	55	M45 x 1.5
BJ-32A	1-1/4	42.7	50	65	M56 x 2.0
BJ-40A	1-1/2	48.6	50	65	M64 x 2.0

Bite Type Tube Fittings

BC

Cap

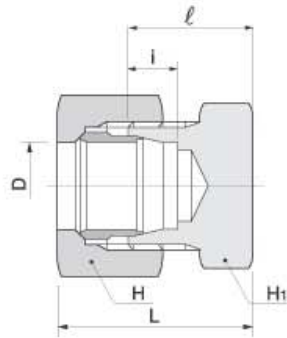
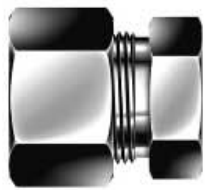

BP

Plug

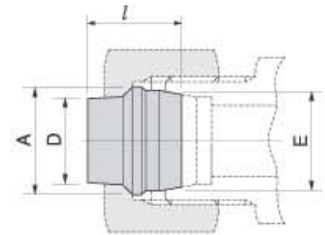
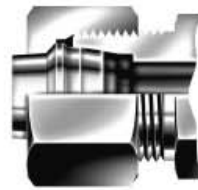

Designations	Tube O.D.		Width across flat		i	l	Approx L
	D	H ₁	H	H ₁			
BC-06	6	14	14	7	18	28.5	
BC-08	8	17	17	7	19	29.5	
BC-10	10	17	19	7	20	31.5	
BC-12	12	19	22	7	20	31.5	
BC-15	15	24	27	7.5	22	34.5	
BC-16	16	27	30	7.5	24	36.5	
BC-18	18	27	32	8	24	36.5	
BC-20	20	30	36	8	24	36.5	
BC-22	22	32	36	9	25	37.5	
BC-25	25	36	41	10	25	38.5	
BC-28	28	41	46	10	28	42	
BC-30	30	41	46	10	28	42.5	
BC-32	32	46	50	11	30	44.5	

Designations	Tube O.D.		E	A	l
	D	H ₁			
BP-06	6	8	9.5	19	
BP-08	8	10	11.5	19	
BP-10	10	12	13.5	19	
BP-12	12	14	15.5	19	
BP-15	15	17	19	20	
BP-16	16	18	20	20	
BP-18	18	20	22.5	20	
BP-20	20	22	25	20	
BP-22	22	24	27	20	
BP-25	25	27.4	30	24	
BP-28	28	30.4	33	24	
BP-30	30	32.4	35.5	24	
BP-32	32	34.4	37.5	24	

Cap for capping tube end

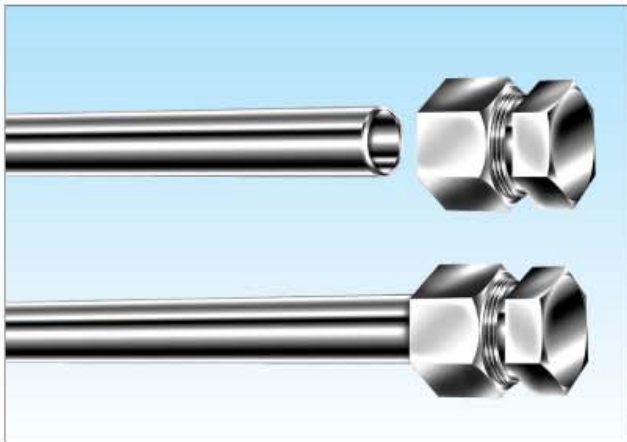

Plug for plugging unused Bite type fitting port

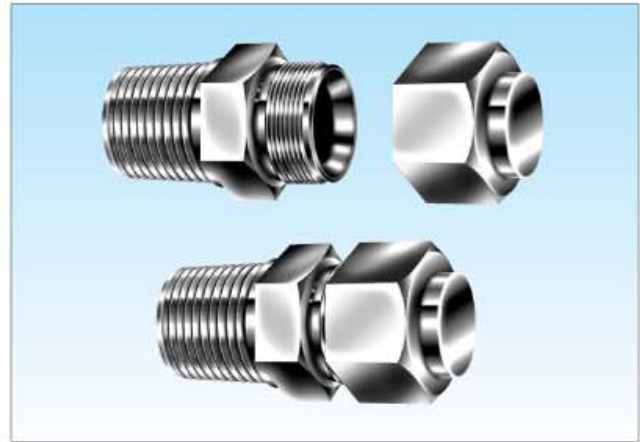

BN

Nut

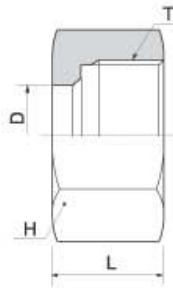

BS

Sleeve

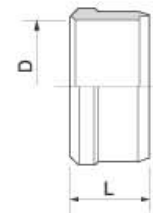

Designations	Tube O.D.		T	Width across flat		L
		D			H	
BN-06		6	M12 x 1.5	14	15	
BN-08		8	M14 x 1.5	17	15	
BN-10		10	M16 x 1.5	19	16	
BN-12		12	M18 x 1.5	22	16	
BN-15		15	M22 x 1.5	27	19	
BN-16		16	M24 x 1.5	30	19	
BN-18		18	M26 x 1.5	32	19	
BN-20		20	M28 x 1.5	36	19	
BN-22		22	M30 x 1.5	36	19	
BN-25		25	M35 x 1.5	41	20	
BN-28		28	M38 x 1.5	46	21	
BN-30		30	M40 x 1.5	46	22	
BN-32		32	M42 x 1.5	50	22	
BN-35		35	M45 x 1.5	55	25	
BN-38		38	M48 x 1.5	60	27	
BN-40		40	M52 x 2.0	60	29.5	
BN-42		42	M52 x 2.0	60	29.5	
BN-06A	1/8	10.5	M16 x 1.5	19	16	
BN-08A	1/4	13.8	M20 x 1.5	24	18	
BN-10A	3/8	17.3	M26 x 1.5	32	19	
BN-15A	1/2	21.7	M30 x 1.5	36	19	
BN-20A	3/4	27.2	M38 x 1.5	46	21	
BN-25A	1	34.0	M45 x 1.5	55	25	
BN-32A	1-1/4	42.7	M56 x 2.0	65	30.5	
BN-40A	1-1/2	48.6	M64 x 2.0	75	31.5	

Designations	Tube O.D.		L
		D	
BS-06		6	9
BS-08		8	9
BS-10		10	10
BS-12		12	10
BS-15		15	10
BS-16		16	10
BS-18		18	10
BS-20		20	10
BS-22		22	10
BS-25		25	11
BS-28		28	11
BS-30		30	11
BS-32		32	11
BS-35		35	14
BS-38		38	14
BS-40		40	14
BS-42		42	14
BS-06A	1/8	10.5	10
BS-08A	1/4	13.8	10
BS-10A	3/8	17.3	10
BS-15A	1/2	21.7	10
BS-20A	3/4	27.2	11
BS-25A	1	34.0	14
BS-32A	1-1/4	42.7	14
BS-40A	1-1/2	48.6	14

Bite Type Tube Fittings

BHUM

Hose Male Union

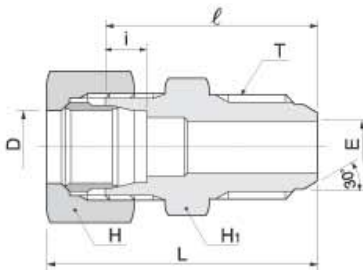
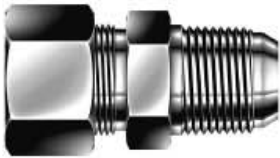

Designations	Tube O.D.	(PF)	E	Width across flat		i	ℓ	Approx L
	D	T		H ₁	H			
BHUM06-01G	6	1/8	4	14	14	7	34	44.5
BHUM08-02G	8	1/4	5.5	17	17	7	35	45.5
BHUM08-03G	8	3/8	6	19	17	7	37	47.5
BHUM10-02G	10	1/4	5.5	17	19	7	35	46.5
BHUM10-03G	10	3/8	8	19	19	7	37	48.5
BHUM10-04G	10	1/2	8	22	19	7	40	51.5
BHUM12-02G	12	1/4	5.5	19	22	7	35	46.5
BHUM12-03G	12	3/8	8	19	22	7	37	48.5
BHUM12-04G	12	1/2	10	22	22	7	40	51.5
BHUM15-03G	15	3/8	8	24	27	7.5	40	52.5
BHUM15-04G	15	1/2	11	24	27	7.5	42	54.5
BHUM16-03G	16	3/8	8	27	30	7.5	40	52.5
BHUM16-04G	16	1/2	11	27	30	7.5	42	54.5
BHUM18-04G	18	1/2	11	27	32	8	42	54.5
BHUM20-06G	20	3/4	16	30	36	8	46	58.5
BHUM22-04G	22	1/2	11	32	36	9	44	56.5
BHUM22-06G	22	3/4	16	32	36	9	46	58.5
BHUM25-06G	25	3/4	16	36	41	10	47	60.5
BHUM25-08G	25	1	20	36	41	10	49	62.5
BHUM28-06G	28	3/4	16	41	46	10	49	63
BHUM28-08G	28	1	21.5	41	46	10	51	65
BHUM30-06G	30	3/4	16	41	46	10	49	63.5
BHUM30-08G	30	1	21.5	41	46	10	51	65.5
BHUM32-08G	32	1	22	46	50	11	52	66.5
BHUM32-10G	32	1-1/4	28	46	50	11	56	70.5

BHUF

Hose Female Union

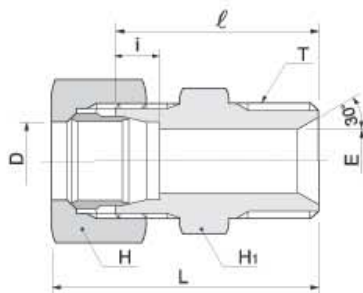

Designations	Tube O.D.	(PF)	E	Width across flat		i	ℓ	Approx L
	D	T		H ₁	H			
BHUF06-01G	6	1/8	4	14	14	7	32	43.5
BHUF08-02G	8	1/4	5.5	17	17	7	33	43.5
BHUF08-03G	8	3/8	6	19	17	7	34	44.5
BHUF10-02G	10	1/4	5.5	17	19	7	33	44.5
BHUF10-03G	10	3/8	8	19	19	7	34	45.5
BHUF10-04G	10	1/2	8	22	19	7	38	49.5
BHUF12-02G	12	1/4	5.5	19	22	7	33	44.5
BHUF12-03G	12	3/8	8	19	22	7	34	45.5
BHUF12-04G	12	1/2	10	22	22	7	38	49.5
BHUF15-03G	15	3/8	8	24	27	7.5	37	49.5
BHUF15-04G	15	1/2	11	24	27	7.5	40	52.5
BHUF16-03G	16	3/8	8	27	30	7.5	37	49.5
BHUF16-04G	16	1/2	11	27	30	7.5	40	52.5
BHUF18-04G	18	1/2	11	27	32	8	40	52.5
BHUF20-06G	20	3/4	16	30	36	8	43	55.5
BHUF22-04G	22	1/2	11	32	36	9	42	54.5
BHUF22-06G	22	3/4	16	32	36	9	43	55.5
BHUF25-06G	25	3/4	16	36	41	10	44	57.5
BHUF25-08G	25	1	20	36	41	10	46	59.5
BHUF28-06G	28	3/4	16	41	46	10	46	60
BHUF28-08G	28	1	21.5	41	46	10	48	62
BHUF30-06G	30	3/4	16	41	46	10	46	60.5
BHUF30-08G	30	1	21.5	41	46	10	48	62.5
BHUF32-08G	32	1	21.5	46	50	11	49	63.5
BHUF32-10G	32	1-1/4	28	46	50	11	55	69.5
BHUF38-12G	38	1-1/2	32	50	60	12	57	76.5
BHUF40-12G	40	1-1/2	32	55	60	12	62	81.5

Bite Type Tube Fittings

BHBM

Hose Bulkhead
Male Union

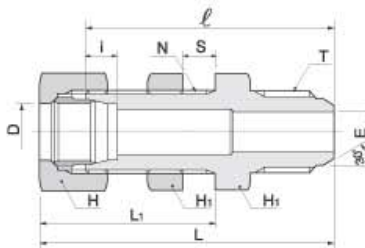

Designations	Tube O.D. (PF)		E	Width across flat		i	l	Approx		Panel Hole Drill Size N	Max. Panel Thickness S
	D	T		H ₁	H			L ₁	L		
BHBM06-01G	6	1/8	4	17	14	7	54	42.5	63.5	12.5	13
BHBM08-02G	8	1/4	5.5	19	17	7	55	42.5	65.5	14.5	13
BHBM08-03G	8	3/8	6	19	17	7	57	42.5	67.5	14.5	13
BHBM10-02G	10	1/4	5.5	22	19	7	56	43.5	67.5	16.5	13
BHBM10-03G	10	3/8	8	22	19	7	58	43.5	69.5	16.5	13
BHBM10-04G	10	1/2	8	22	19	7	60	43.5	71.5	16.5	13
BHBM12-02G	12	1/4	5.5	24	22	7	56	43.5	67.5	18.5	13
BHBM12-03G	12	3/8	8	24	22	7	58	43.5	69.5	18.5	13
BHBM12-04G	12	1/2	10	24	22	7	60	43.5	71.5	18.5	13
BHBM15-03G	15	3/8	8	27	27	7.5	63	49.5	75.5	22.5	15
BHBM15-04G	15	1/2	11	27	27	7.5	65	49.5	77.5	22.5	15
BHBM16-03G	16	3/8	8	30	30	7.5	65	49.5	77.5	24.5	15
BHBM16-04G	16	1/2	11	30	30	7.5	67	49.5	79.5	24.5	15
BHBM18-04G	18	1/2	11	32	32	8	69	51.5	81.5	26.5	15
BHBM20-06G	20	3/4	16	32	36	8	71	51.5	83.5	28.5	15
BHBM22-04G	22	1/2	11	36	36	9	70	51.5	82.5	30.5	15
BHBM22-06G	22	3/4	16	36	36	9	72	51.5	84.5	30.5	15
BHBM25-06G	25	3/4	16	41	41	10	72	52.5	87.5	35.5	15
BHBM25-08G	25	1	20	41	41	10	74	52.5	89.5	35.5	15
BHBM28-06G	28	3/4	16	46	46	10	75	55	89	38.5	15
BHBM28-08G	28	1	21.5	46	46	10	77	55	91	38.5	15
BHBM30-06G	30	3/4	16	46	46	10	75	55.5	89.5	40.5	15
BHBM30-08G	30	1	21.5	46	46	10	77	55.5	91.5	40.5	15
BHBM32-08G	32	1	22	50	50	11	81	57.5	95.5	42.5	15
BHBM32-10G	32	1-1/4	28	50	50	11	85	57.5	99.5	42.5	15

BHBF

Hose Bulkhead
Female Union

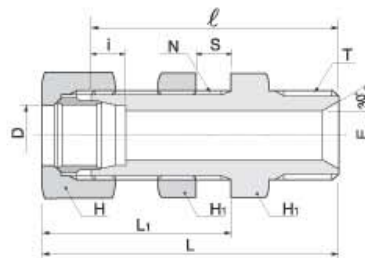
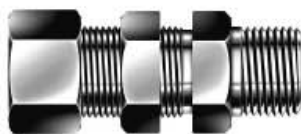

Designations	Tube O.D. (PF)		E	Width across flat		i	l	Approx		Panel Hole Drill Size N	Max. Panel Thickness S
	D	T		H ₁	H			L ₁	L		
BHBF06-01G	6	1/8	4	17	14	7	52	42.5	62.5	12.5	13
BHBF08-02G	8	1/4	5.5	19	17	7	53	42.5	63.5	14.5	13
BHBF08-03G	8	3/8	6	19	17	7	54	42.5	64.5	14.5	13
BHBF10-02G	10	1/4	5.5	22	19	7	54	43.5	65.5	16.5	13
BHBF10-03G	10	3/8	8	22	19	7	55	43.5	66.5	16.5	13
BHBF10-04G	10	1/2	8	22	19	7	58	43.5	69.5	16.5	13
BHBF12-02G	12	1/4	5.5	24	22	7	54	43.5	65.5	18.5	13
BHBF12-03G	12	3/8	8	24	22	7	55	43.5	66.5	18.5	13
BHBF12-04G	12	1/2	10	24	22	7	58	43.5	69.5	18.5	13
BHBF15-03G	15	3/8	8	27	27	7.5	60	49.5	72.5	22.5	15
BHBF15-04G	15	1/2	11	27	27	7.5	63	49.5	75.5	22.5	15
BHBF16-03G	16	3/8	8	30	30	7.5	62	49.5	74.5	24.5	15
BHBF16-04G	16	1/2	11	30	30	7.5	65	49.5	77.5	24.5	15
BHBF18-04G	18	1/2	11	32	32	8	67	51.5	79.5	26.5	15
BHBF20-06G	20	3/4	16	32	36	8	68	51.5	80.5	28.5	15
BHBF22-04G	22	1/2	11	36	36	9	68	51.5	80.5	30.5	15
BHBF22-06G	22	3/4	16	36	36	9	69	51.5	81.5	30.5	15
BHBF25-06G	25	3/4	16	41	41	10	69	52.5	82.5	35.5	15
BHBF25-08G	25	1	20	41	41	10	71	52.5	84.5	35.5	15
BHBF28-08G	28	1	21.5	46	46	10	74	55	88	38.5	15
BHBF30-06G	30	3/4	16	46	46	10	72	55.5	86.5	40.5	15
BHBF30-08G	30	1	21.5	46	46	10	74	55.5	88.5	40.5	15
BHBF32-08G	32	1	22	50	50	11	78	57.5	92.5	42.5	15
BHBF32-10G	32	1-1/4	28	50	50	11	84	57.5	98.5	42.5	15
BHBF38-12G	38	1-1/2	31	55	60	12	87	64.5	106.5	48.5	15
BHBF40-12G	40	1-1/2	32	60	60	12	94	69.5	113.5	52.5	15

Bite Type Tube Fittings

BHLM

Hose Male Elbow

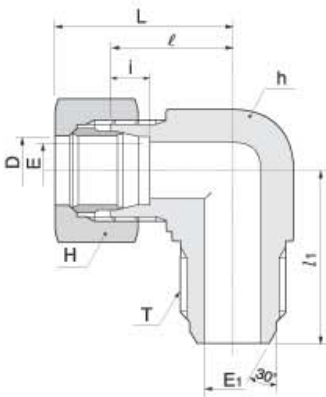

Designations	Tube O.D. (PF)		E	E ₁	Width across flat		i	ℓ	l ₁	Approx L
	D	T			h	H				
BHLM06-01G	6	1/8	4	4	14	14	7	20	25	33.5
BHLM08-02G	8	1/4	6	5.5	17	17	7	23	25	33.5
BHLM08-03G	8	3/8	6	8	19	17	7	24	28	34.5
BHLM10-02G	10	1/4	8	5.5	19	19	7	24	28	35.5
BHLM10-03G	10	3/8	8	8	19	19	7	24	28	35.5
BHLM10-04G	10	1/2	8	11	24	19	7	29	34	40.5
BHLM12-02G	12	1/4	10	5.5	19	22	7	24	28	35.5
BHLM12-03G	12	3/8	10	8	19	22	7	24	28	35.5
BHLM12-04G	12	1/2	10	11	24	22	7	29	34	40.5
BHLM15-03G	15	3/8	12	8	24	27	7.5	29	33	41.5
BHLM15-04G	15	1/2	12	11	24	27	7.5	29	34	41.5
BHLM16-03G	16	3/8	13	8	27	30	7.5	32	36	44.5
BHLM16-04G	16	1/2	13	11	27	30	7.5	32	38	44.5
BHLM18-04G	18	1/2	14	11	27	32	8	32	38	44.5
BHLM20-06G	20	3/4	17	16	30	36	8	33	41	45.5
BHLM22-04G	22	1/2	18	11	32	36	9	34	40	46.5
BHLM22-06G	22	3/4	18	16	32	36	9	34	42	46.5
BHLM25-06G	25	3/4	20	16	36	41	10	36	44	49.5
BHLM25-08G	25	1	20	21.5	36	41	10	36	46	49.5
BHLM28-06G	28	3/4	22	16	41	46	10	41	47	55
BHLM28-08G	28	1	22	21.5	41	46	10	41	49	55
BHLM30-06G	30	3/4	25	16	41	46	10	41	47	55.5
BHLM30-08G	30	1	25	21.5	41	46	10	41	49	55.5
BHLM32-08G	32	1	26	22	46	50	11	46	54	60.5
BHLM32-10G	32	1-1/4	26	28	46	50	11	46	56	60.5

BHLF

Hose Female Elbow

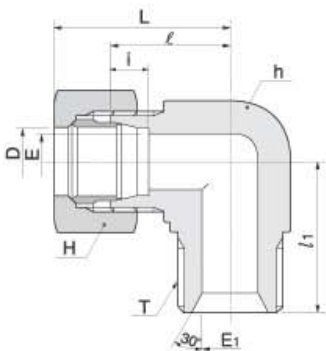

Designations	Tube O.D. (PF)		E	E ₁	Width across flat		i	ℓ	l ₁	Approx L
	D	T			h	H				
BHLF08-02G	8	1/4	6	5.5	17	17	7	23	25	33.5
BHLF08-03G	8	3/8	6	8	19	17	7	24	27	34.5
BHLF10-02G	10	1/4	8	5.5	19	19	7	24	26	35.5
BHLF10-03G	10	3/8	8	8	19	19	7	24	27	35.5
BHLF10-04G	10	1/2	8	11	24	19	7	29	23	40.5
BHLF12-02G	12	1/4	10	5.5	19	22	7	24	26	35.5
BHLF12-03G	12	3/8	10	8	19	22	7	24	27	35.5
BHLF12-04G	12	1/2	10	11	24	22	7	29	33	40.5
BHLF15-03G	15	3/8	12	8	24	27	7.5	29	30	41.5
BHLF15-04G	15	1/2	12	11	24	27	7.5	29	33	41.5
BHLF16-03G	16	3/8	13	8	27	30	7.5	32	33	44.5
BHLF16-04G	16	1/2	13	11	27	30	7.5	32	36	44.5
BHLF18-04G	18	1/2	14	11	27	32	8	32	36	44.5
BHLF20-06G	20	3/4	17	16	30	36	8	33	38	45.5
BHLF22-04G	22	1/2	18	11	32	36	9	34	38	46.5
BHLF22-06G	22	3/4	18	16	32	36	9	34	39	46.5
BHLF25-06G	25	3/4	20	16	36	41	10	36	41	49.5
BHLF25-08G	25	1	20	21.5	36	41	10	36	43	49.5
BHLF28-06G	28	3/4	22	16	41	46	10	41	44	55
BHLF28-08G	28	1	22	21.5	41	46	10	41	46	55
BHLF30-06G	30	3/4	25	16	41	46	10	41	44	55.5
BHLF30-08G	30	1	25	21.5	41	46	10	41	46	55.5
BHLF32-08G	32	1	26	22	46	50	11	46	51	60.5
BHLF32-10G	32	1-1/4	26	28	46	50	11	46	57	60.5
BHLF38-12G	38	1-1/2	32	34	50	60	12	50	61	69.5
BHLF40-12G	40	1-1/2	32	34	55	60	12	55	62	74.5

BHBLM

Hose Bulkhead
Male Elbow

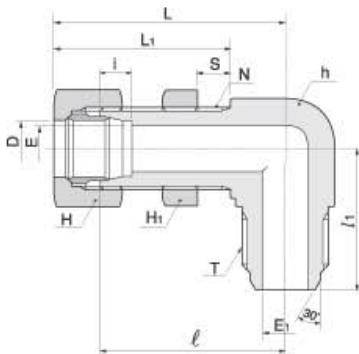

Designations	Tube O.D. (PF)		E	E ₁	Width across flat			i	ℓ	l ₁	Approx		Panel Hole Drill Size N	Max. Panel Thickness S
	D	T			h	H ₁	H				L ₁	L		
BHBLM06-01G	6	1/8	4	4	17	17	14	7	45	28	42.5	56.5	14.5	13
BHBLM08-02G	8	1/4	6	5.5	19	19	17	7	46	28	42.5	56.5	14.5	13
BHBLM08-03G	8	3/8	6	8	19	19	17	7	46	30	42.5	56.5	14.5	13
BHBLM10-02G	10	1/4	8	5.5	22	22	19	7	48	30	43.5	59.5	16.5	13
BHBLM10-03G	10	3/8	8	8	22	22	19	7	48	32	43.5	59.5	16.5	13
BHBLM10-04G	10	1/2	8	11	24	22	19	7	49	35	43.5	60.5	16.5	13
BHBLM12-02G	12	1/4	10	5.5	24	24	22	7	49	31	43.5	60.5	18.5	13
BHBLM12-03G	12	3/8	10	8	24	24	22	7	49	33	43.5	60.5	18.5	13
BHBLM12-04G	12	1/2	10	11	24	24	22	7	49	35	43.5	60.5	18.5	13
BHBLM15-03G	15	3/8	12	8	27	27	27	7.5	57	36	49.5	69.5	22.5	15
BHBLM15-04G	15	1/2	12	11	27	27	27	7.5	57	37	49.5	69.5	22.5	15
BHBLM16-03G	16	3/8	13	8	30	30	30	7.5	59	37	49.5	71.5	24.5	15
BHBLM16-04G	16	1/2	13	11	30	30	30	7.5	59	38	49.5	71.5	24.5	15
BHBLM18-04G	18	1/2	14	11	32	32	32	8	63	39	51.5	75.5	26.5	15
BHBLM20-06G	20	3/4	16	16	36	36	36	8	65	40	51.5	77.5	28.5	15
BHBLM22-04G	22	1/2	18	11	36	36	36	9	65	40	51.5	77.5	30.5	15
BHBLM22-06G	22	3/4	18	16	36	36	36	9	65	40	51.5	77.5	30.5	15
BHBLM25-06G	25	3/4	20	16	41	41	41	10	68	43	52.5	81.5	35.5	15
BHBLM25-08G	25	1	20	21.5	41	41	41	10	68	48	52.5	81.5	35.5	15
BHBLM28-06G	28	3/4	22	16	46	46	46	10	74	48	55	88	38.5	15
BHBLM28-08G	28	1	22	21.5	46	46	46	10	74	48	55	88	38.5	15
BHBLM30-06G	30	3/4	25	16	46	46	46	10	74	48	55.5	88.5	40.5	15
BHBLM30-08G	30	1	25	21.5	46	46	46	10	74	51	55.5	88.5	40.5	15

BHBLF

Hose Bulkhead
Female Elbow

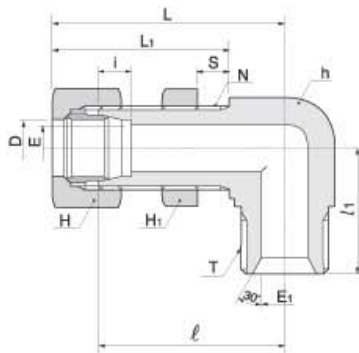

Designations	Tube O.D. (PF)		E	E ₁	Width across flat			i	ℓ	l ₁	Approx		Panel Hole Drill Size N	Max. Panel Thickness S
	D	T			h	H ₁	H				L ₁	L		
BHBLF06-01G	6	1/8	4	4	17	17	14	7	45	28	42.5	56.5	14.5	13
BHBLF08-02G	8	1/4	6	5.5	19	19	17	7	46	26	42.5	56.5	14.5	13
BHBLF08-03G	8	3/8	6	8	19	19	17	7	46	27	42.5	56.5	14.5	13
BHBLF10-02G	10	1/4	8	5.5	22	22	19	7	48	28	43.5	59.5	16.5	13
BHBLF10-03G	10	3/8	8	8	22	22	19	7	48	29	43.5	59.5	16.5	13
BHBLF10-04G	10	1/2	8	11	24	22	19	7	49	33	43.5	60.5	16.5	13
BHBLF12-02G	12	1/4	10	5.5	24	24	22	7	49	30	43.5	60.5	18.5	13
BHBLF12-03G	12	3/8	10	8	24	24	22	7	49	30	43.5	60.5	18.5	13
BHBLF12-04G	12	1/2	10	11	24	24	22	7	49	33	43.5	60.5	18.5	13
BHBLF15-03G	15	3/8	12	8	27	27	27	7.5	57	33	49.5	69.5	22.5	15
BHBLF15-04G	15	1/2	12	11	27	27	27	7.5	57	36	49.5	69.5	22.5	15
BHBLF16-03G	16	3/8	13	8	30	30	30	7.5	59	34	49.5	71.5	24.5	15
BHBLF16-04G	16	1/2	13	11	30	30	30	7.5	59	37	49.5	71.5	24.5	15
BHBLF18-04G	18	1/2	14	11	32	32	32	8	63	37	51.5	75.5	26.5	15
BHBLF20-06G	20	3/4	16	16	32	32	36	8	65	40	51.5	77.5	28.5	15
BHBLF22-04G	22	1/2	18	11	36	36	36	9	65	40	51.5	77.5	30.5	15
BHBLF22-06G	22	3/4	18	16	36	36	36	9	65	40	51.5	77.5	30.5	15
BHBLF25-06G	25	3/4	20	16	41	41	41	10	68	43	52.5	81.5	35.5	15
BHBLF25-08G	25	1	20	21.5	41	41	41	10	68	43	52.5	81.5	35.5	15
BHBLF28-06G	28	3/4	22	16	46	46	46	10	74	48	55	88	38.5	15
BHBLF28-08G	28	1	22	21.5	46	46	46	10	74	48	55	88	38.5	15
BHBLF30-06G	30	3/4	25	16	46	46	46	10	74	48	55.5	88.5	40.5	15
BHBLF30-08G	30	1	25	21.5	46	46	46	10	74	48	55.5	88.5	40.5	15

Bite Type Tube Fittings

BCW

Welding Connector

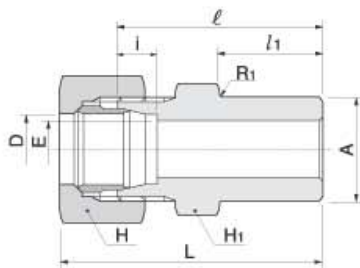

Designations	Tube O.D.		A	E	Width across flat		ℓ	i	l ₁	Approx L
	D				H ₁	H				
BCW-06	6		12	4	14	14	29	7	11	39.5
BCW-08	8		14	6	17	17	34	7	15	44.5
BCW-10	10		16	8	17	19	34	7	15	45.5
BCW-12	12		18	10	19	22	34	7	15	45.5
BCW-15	15		21	12	24	27	40	7.5	18	52.5
BCW-16	16		22	13	27	30	44	7.5	22	56.5
BCW-18	18		25	14	27	32	44	8	22	56.5
BCW-20	20		28	17	30	36	46	8	22	58.5
BCW-22	22		28	18	32	36	46	9	22	58.5
BCW-25	25		33	20	36	41	51	10	26	64.5
BCW-28	28		36	22	41	46	55	10	28	69
BCW-30	30		39	25	41	46	55	10	28	69.5
BCW-32	32		40	26	46	50	56	11	28	70.5
BCW-35	35		43	28	46	55	56	11	28	73.5
BCW-38	38		45	32	50	60	58	12	28	77.5
BCW-40	40		46	32	55	60	65	12	30	84.5
BCW-06A	1/8	10.5	16	8	17	19	34	7	15	45.5
BCW-08A	1/4	13.8	19	11	22	24	40	7.5	18	52
BCW-10A	3/8	17.3	24	14	27	32	44	8	22	56.5
BCW-15A	1/2	21.7	28	18	32	36	46	9	22	58.5
BCW-20A	3/4	27.2	33	22	41	46	52	10	25	66
BCW-25A	1	34.0	40	28	46	55	56	11	28	73.5
BCW-32A	1-1/4	42.7	47	34	60	65	65	12	28	85.5
BCW-40A	1-1/2	48.6	55	40	65	75	70	12	30	91.5

BBUW

Welding Bulkhead Union

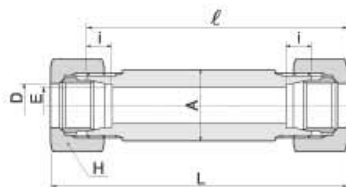

Designations	Tube O.D.		A	E	Width across flat		ℓ	i	Approx L
	D				H				
BBUW-06	6		16	4	14	14	74	7	95
BBUW-08	8		16	6	17	17	74	7	95
BBUW-10	10		19	8	19	19	74	7	97
BBUW-12	12		20	10	22	22	74	7	97
BBUW-15	15		25	12	27	27	78	7.5	103
BBUW-16	16		28	13	30	30	78	7.5	103
BBUW-18	18		28	14	32	32	78	8	103
BBUW-20	20		32	17	36	36	78	8	103
BBUW-22	22		32	18	36	36	78	9	103
BBUW-25	25		38	20	41	41	78	10	105
BBUW-28	28		39	22	46	46	82	10	110
BBUW-30	30		46	25	46	46	82	10	111
BBUW-32	32		46	26	50	50	82	11	111
BBUW-35	35		46	28	55	55	82	11	117
BBUW-38	38		55	32	60	60	82	12	121
BBUW-40	40		55	32	60	60	90	12	129
BBUW-06A	1/8	10.5	19	8	19	19	74	7	97
BBUW-08A	1/4	13.8	22	11	24	24	78	7.5	102
BBUW-10A	3/8	17.3	28	14	32	32	78	8	103
BBUW-15A	1/2	21.7	32	18	36	36	78	9	103
BBUW-20A	3/4	27.2	39	22	46	46	82	10	110
BBUW-25A	1	34.0	46	28	55	55	82	11	117
BBUW-32A	1-1/4	42.7	58	34	65	65	90	12	131
BBUW-40A	1-1/2	48.6	65	40	75	75	90	12	133

BA-R

Adapter

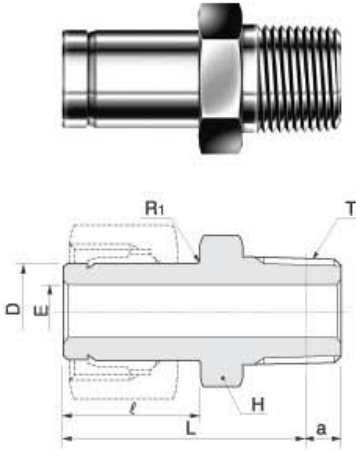

Designations	Tube O.D.		(PT)	E	Basic Gauge length a	Width across flat		Approx L
	D	T				H	ℓ	
BA06-01R	6	1/8	3	3	3.97	12	20	32
BA08-02R	8	1/4	5	5	6.01	14	20	35
BA10-02R	10	1/4	6	6	6.01	14	21	36
BA10-03R	10	3/8	6	6	6.35	19	21	36.5
BA12-02R	12	1/4	7	7	6.01	14	22	37
BA12-03R	12	3/8	8	8	6.35	19	22	37.5
BA15-03R	15	3/8	8	8	6.35	19	24	40.5
BA15-04R	15	1/2	10	10	8.16	22	24	43
BA16-04R	16	1/2	11	11	8.16	22	24	43
BA18-04R	18	1/2	12	12	8.16	22	24	43
BA20-06R	20	3/4	14	14	9.53	27	25	46.5
BA22-06R	22	3/4	14	14	9.53	27	26	47.5
BA25-06R	25	3/4	16	16	9.53	27	28	49.5
BA25-08R	25	1	17	17	10.39	36	28	52.5
BA28-08R	28	1	18	18	10.39	36	28	52.5
BA30-08R	30	1	20	20	10.39	36	29	53.5
BA30-10R	30	1-1/4	20	20	12.70	46	29	55
BA32-10R	32	1-1/4	22	22	12.70	46	30	56
BA38-12R	38	1-1/2	26	26	12.70	50	36	64.5
BA40-12R	40	1-1/2	28	28	12.70	50	36	64
BA06A-02R	1/8	10.5	1/4	6	6.01	14	21	36
BA08A-03R	1/4	13.8	3/8	9	6.35	19	22	38.5
BA10A-04R	3/8	17.3	1/2	11	8.16	22	24	43
BA15A-06R	1/2	21.7	3/4	14	9.53	27	26	47.5
BA20A-08R	3/4	27.2	1	18	10.39	36	28	52.5
BA25A-10R	1	34.0	1-1/4	23	12.70	46	33	59
BA32A-12R	1-1/4	42.7	1-1/2	29	12.70	50	36	67
BA40A-16R	1-1/2	48.6	2	33	15.88	65	37	72

BA-G

Adapter

(For Copper Gasket)

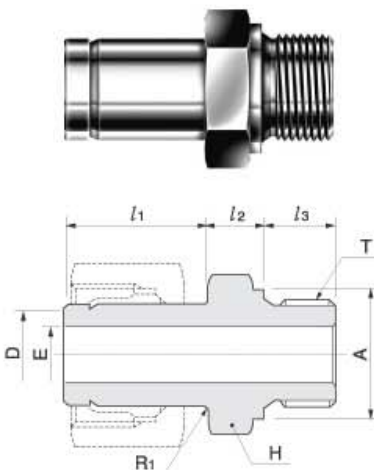

Designations	Tube O.D.		(PF)	E	Width across flat		Approx		
	D	T			H	A	l ₁	l ₂	l ₃
BA06-01G	6	1/8	3	3	14	14	20	8	8
BA08-02G	8	1/4	5	5	19	18	20	9	12
BA10-02G	10	1/4	6	6	19	18	21	9	12
BA10-03G	10	3/8	6	6	22	21.5	21	10	12
BA12-02G	12	1/4	7	7	19	18	22	9	12
BA12-03G	12	3/8	8	8	22	21.5	22	10	12
BA15-03G	15	3/8	8	8	22	21.5	24	10	12
BA15-04G	15	1/2	10	10	27	25.5	24	13	14
BA16-04G	16	1/2	11	11	27	25.5	24	13	14
BA18-04G	18	1/2	12	12	27	25.5	24	13	14
BA20-06G	20	3/4	14	14	32	31.5	25	16	16
BA22-06G	22	3/4	14	14	32	31.5	26	16	16
BA25-06G	25	3/4	16	16	32	31.5	28	16	16
BA25-08G	25	1	17	17	41	38	28	18	18
BA28-08G	28	1	18	18	41	38	28	18	18
BA30-08G	30	1	20	20	41	38	29	21	18
BA30-10G	30	1-1/4	20	20	50	48.5	29	21	20
BA32-10G	32	1-1/4	22	22	50	48.5	30	21	20
BA38-12G	38	1-1/2	26	26	55	53.5	36	21	21
BA40-12G	40	1-1/2	28	28	55	53.5	36	21	21
BA06A-02G	1/8	10.5	1/4	6	19	18	21	9	12
BA08A-03G	1/4	13.8	3/8	9	22	21.5	22	10	12
BA10A-04G	3/8	17.3	1/2	11	27	25.5	24	13	14
BA15A-06G	1/2	21.7	3/4	14	32	31.5	26	16	16
BA20A-08G	3/4	27.2	1	18	41	38	28	18	18
BA25A-10G	1	34.0	1-1/4	23	50	48.5	33	21	20
BA32A-12G	1-1/4	42.7	1-1/2	29	55	53.5	36	23	21
BA40A-16G	1-1/2	48.6	2	33	70	66	37	28	24

Male Stud Form B
sealing by copper
gasket
See page 6

Bite Type Tube Fittings

BR

Reducer

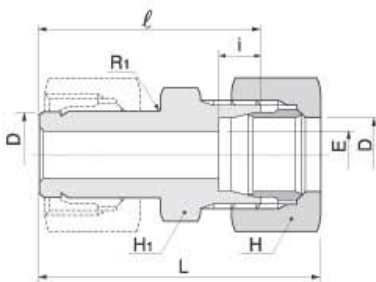
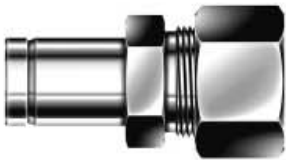

Designations	Tube O.D.		E	Width across flat		i	ℓ	Approx L		
	D ₁	D		H ₁	H					
BR08-06	8	6	4	14	14	7	39	49.5		
BR10-06	10	6	4	14	14	7	40	50.5		
BR10-08	10	8	6	17	17	7	40	50.5		
BR12-06	12	6	4	14	14	7	41	51.5		
BR12-08	12	8	6	17	17	7	41	51.5		
BR12-10	12	10	8	17	19	7	41	52.5		
BR15-08	15	8	6	17	17	7	43	53.5		
BR15-10	15	10	8	17	19	7	43	54.5		
BR16-06	16	6	4	17	14	7	43	53.5		
BR16-10	16	10	8	17	19	7	43	54.5		
BR16-12	16	12	10	19	22	7	43	54.5		
BR18-10	18	10	8	19	19	7	44	55.5		
BR18-15	18	15	12	24	27	7.5	45	57.5		
BR20-06	20	6	4	22	14	7	45	55.5		
BR20-12	20	12	10	22	22	7	45	56.5		
BR20-16	20	16	13	27	30	7.5	47	59.5		
BR22-15	22	15	12	24	27	7.5	48	60.5		
BR22-18	22	18	14	27	32	8	48	60.5		
BR25-16	25	16	13	27	30	7.5	50	62.5		
BR25-20	25	20	17	30	36	8	52	64.5		
BR28-18	28	18	14	30	32	8	52	64.5		
BR28-22	28	22	18	32	36	9	52	64.5		
BR30-20	30	20	17	32	36	8	53	65.5		
BR30-25	30	25	20	36	41	10	54	67.5		
BR32-25	32	25	20	36	41	10	55	68.5		
BR35-22	35	22	18	36	36	9	58	70.5		
BR35-28	35	28	22	36	46	10	60	74		
BR38-25	38	25	20	41	41	10	61	74.5		
BR38-30	38	30	25	41	46	10	63	77.5		
BR08A-6A	1/4	13.8	1/8	10.5	8	17	19	7	41	52.5
BR10A-6A	3/8	17.3	1/8	10.5	8	19	19	7	44	55.5
BR10A-8A	3/8	17.3	1/4	13.8	11	22	24	7.5	46	58
BR15A-8A	1/2	21.7	1/4	13.8	11	24	24	7.5	48	60
BR15A-10A	1/2	21.7	3/8	17.3	14	27	32	8	48	60.5
BR20A-10A	3/4	27.2	3/8	17.3	14	30	32	8	52	64.5
BR20A-15A	3/4	27.2	1/2	21.7	18	32	36	9	52	64.5
BR25A-15A	1	34	1/2	21.7	18	36	36	9	58	70.5
BR25A-20A	1	34	3/4	27.2	22	41	46	10	60	74

BLA

Positionable Elbow

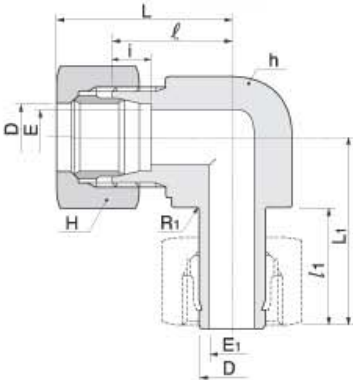

Designations	Tube O.D.		E	E ₁	Width across flat		i	ℓ	l ₁	Approx	
	D	D			h	H				L	L ₁
BLA-10	10	8	6	17	19	7	23	21	34.5	35	
BLA-12	12	10	8	19	22	7	24	22	35.5	37	
BLA-15	15	12	10	24	27	7.5	29	24	44.5	40	
BLA-16	16	13	11	27	30	7.5	32	24	44.5	43	
BLA-18	18	14	12	27	32	8	32	24	44.5	43	
BLA-20	20	17	14	30	36	8	33	25	45.5	45	
BLA-22	22	18	14	32	36	9	34	26	46.5	46	
BLA-25	25	20	17	36	41	10	36	28	49.5	49	
BLA-28	28	22	18	41	46	10	41	28	55	53	
BLA-30	30	25	20	41	46	10	41	29	55.5	54	
BLA-32	32	26	22	46	50	11	50	30	64.5	66	
BLA-38	38	32	26	50	60	12	50	36	69.5	72	

BBTA

Positionable Branch Tee

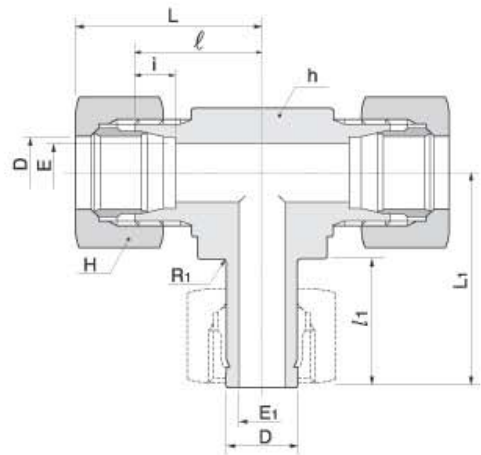

Designations	Tube O.D. D	E	E ₁	Width across flat		i	ℓ	l ₁	Approx	
				h	H				L	L ₁
BBTA-10	10	8	6	17	19	7	23	21	34.5	35
BBTA-12	12	10	8	19	22	7	24	22	35.5	37
BBTA-15	15	12	10	24	27	7.5	32	24	44.5	43
BBTA-16	16	13	11	27	30	7.5	32	24	44.5	43
BBTA-18	18	14	12	27	32	8	32	24	44.5	43
BBTA-20	20	17	14	30	36	8	33	25	45.5	45
BBTA-22	22	18	14	32	36	9	34	26	46.5	46
BBTA-25	25	20	17	36	41	10	36	28	49.5	49

BRTA

Positionable Run Tee

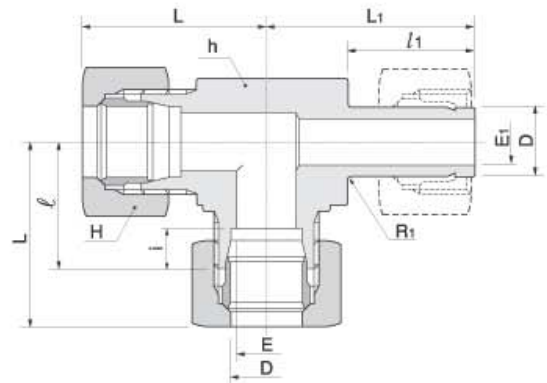

Designations	Tube O.D. D	E	E ₁	Width across flat		i	ℓ	l ₁	Approx	
				h	H				L	L ₁
BRTA-10	10	8	6	17	19	7	23	21	34.5	35
BRTA-12	12	10	8	19	22	7	24	22	35.5	37
BRTA-15	15	12	10	24	27	7.5	32	24	44.5	43
BRTA-16	16	13	11	27	30	7.5	32	24	44.5	43
BRTA-18	18	14	12	27	32	8	32	24	44.5	43
BRTA-20	20	17	14	30	36	8	33	25	45.5	45
BRTA-22	22	18	14	32	36	9	34	26	46.5	46
BRTA-25	25	20	17	36	41	10	36	28	49.5	49

Bite Type Tube Fittings

BAP-1

Air Purge Valve (Tube End)

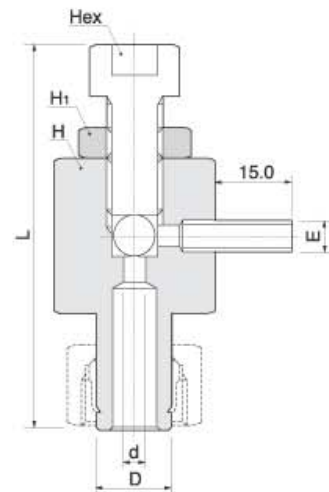
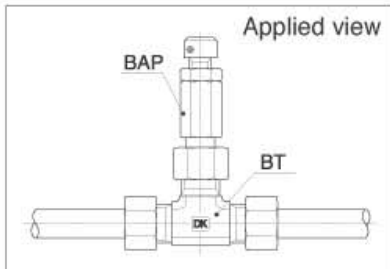

Designations	D	E	d	Width across flat		L	Ball
				H ₁	H		
BAP-06	6	4	3	13	14	56	7/32
BAP-08	8	4	3	13	14	56	7/32
BAP-10	10	4	3	13	14	57	7/32
BAP-12	12	4	3	13	14	58	7/32
BAP-15	15	6	4	19	27	74	5/16
BAP-16	16	6	4	19	27	74	5/16
BAP-18	18	6	4	19	27	74	5/16
BAP-20	20	6	4	19	27	75	5/16
BAP-22	22	6	4	19	27	76	5/16
BAP-25	25	6	4	19	27	78	5/16
BAP-28	28	6	4	19	30	78	5/16
BAP-06A	1/8	10.5	4	13	14	57	7/32
BAP-08A	1/4	13.8	6	19	27	72	5/16
BAP-10A	3/8	17.3	6	19	27	74	5/16
BAP-15A	1/2	21.7	6	19	27	76	5/16
BAP-20A	3/4	27.2	6	19	30	79	5/16

BAP-2

Air Purge Valve (Thread End)

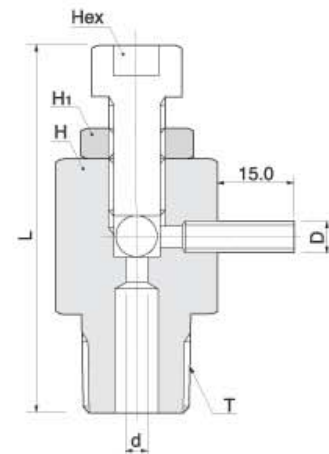

Designations	(PT) T	E	d	Width across flat		L	Ball
				H ₁	H		
BAP-01R	1/8	4	3	13	14	51	7/32
BAP-02R	1/4	4	3	13	14	53	7/32
BAP-03R	3/8	6	4	13	19	54	7/32
BAP-04R	1/2	6	4	19	27	69	5/16

Bite Type Fitting Material Chemical & Mechanical Properties in different Code

Fitting Material	Chemical Compositions					Mechanical Properties			
	C %	Si %	Mn %	P %	S %	Tensile Strength Kgf/mm ²	Yield Point Kgf/mm ²	Elongation %	Hardness HB
JIS G4051 S45C	0.42~0.48	0.15~0.45	0.60~0.90	0.030 MAX.	0.035 MAX.	58 (MIN.)	35 (MIN.)	20 (MIN.)	167~229 Normalizing
AISI G1045 & SAE1045	0.43~0.50	0.10~0.20	0.60~0.90	0.040 MAX.	0.050 MAX.	56	49	15	163
DIN 1652 C45	0.42~0.50	0.15~0.35	0.50~0.80	0.045 MAX.	0.045 MAX.	60 (MIN.)	34 (MIN.)	18 (MIN.)	206(MIN.) Normalizing

Applicable Tubing

The listed below is recommended.

Unit: mm

Tube	Thickness Tolerance	0.5	1.0	1.5	2.0	2.5	3.0	3.3	3.5	4.0	4.5	5.0	5.5	6.0	7.0	8.0	9.0
		± 0.1	± 0.15	± 0.2	± 0.2	± 0.25	± 0.3	± 0.33	± 0.35	± 0.4	± 0.45	± 0.5	± 0.55	± 0.6	± 0.7		
O.D.	O.D. Tolerance																
4	±0.1	○	○														
6			○	○													
8			○	○													
10			○	○	○												
12			○	○		○											
15				○		○											
16				○	○		○										
18						○		○									
20					○	○			○								
22					○			○		○							
25	±0.15						○				○						
28							○		○			○					
30							○			○			○				
35								○			○			○			
38							○			○	○				○		
42	±0.2					○				○			○			○	
50								○			○			○		○	

Note: 1. The Dark area in the table indicates tube thickness to corresponding tube outer diameters as per JOHS-102-1964-Hydraulic Line Service.
 2. Tube Thickness indicated by O mark is recommended.



Bite Type Fitting Type Approval Certifications

LR	01 / 10048
DNV	P13044
GL	40 505 - 01 HH
ABS	BK720958 - X
BV	14034 / A1
NK	TA06112M
KR	CWN80397 - PE001

Safe Component Selection

The Selection of component for any applications or system design must be considered to ensure safe performance. Component function, material compatibility, component ratings, proper installation, operation and maintenance remain the sole responsibility of the system designer and the user. DK Tech accepts no liability for any improper selection, installation, operation or maintenance.



Dk Tech Corporation

Head Quarters and Factory
826, Naesam-Ri, JuChon-Myeon, Kimhae-city, South Korea 621-841
Phone : 82) 55-338-0114
Fax : 82) 55-338-6743 / 6744 / 6745 / 6746

D-Pro[®] Dk-Lok[®] Green[®]